

Touristische Signalisation *Segnaletica turistica*

5

und Strassennamen
e toponomastica

Poststrasse 34 ▶

 Le Chalais

 Aminona

1 Std. 45 Min. über Brieggl 1152 m
2 Std. 2 Std.
2 Std. 15 Min. Schauenburg Hasenmatt Weissenstein 30 Min. 1 Std. 30 Min. 2 Std. 50 Min.

 Genève 
 Nyon  
 Morges 



SIGNAL AG
3294 Büren a/A
IZ kleine Ey
Tel. 032 352 11 11
Fax 032 352 11 01
info@signal.ch

SIGNAL SA
6514 Sementina
Via Pobbia 4
Tel. 091 780 46 60
Fax 091 780 46 61
ticino@signal.ch

www.signal.ch



Segnaletica Mordasini SA
6514 Sementina
Via Pobbia 4
Tel. 091 857 58 92
Fax 091 857 78 34
info@segnaletica-mordasini.ch

www.segnaletica-mordasini.ch

Wir beraten und signalisieren nach gültigen VSS-Normen (SN / EN) und der Signalisationsverordnung SSV.

Vi consigliamo e segnaliamo conformemente alle norme VSS (SN/EN) e all'ordinanza sulla segnaletica stradale in vigore.

Klassen und Ausgestaltung von Signalen (SN 640 871)

Categorie e tipi di segnali (SN 640 871)

Klasse/Classe	Ausgestaltung/Configurazione
R1	Retroreflektierend/Retroriflettente
R2	Stark retroreflektierend/Molto retroriflettente
R3	Sehr stark retroreflektierend/Altamente retroriflettente

Mindestanforderungen für retroreflektierende Signale auf Haupt- und Nebenstrassen

Requisiti minimi richiesti ai segnali in materia di retroriflettenza su strade principali e secondarie

Strasstyp <i>Tipa di strada</i>	Signale für den fliessenden Verkehr <i>Segnali per traffico scorrevole</i>			Signale für den ruhenden Verkehr <i>Segnali per il traffico lento</i>
	Strassenrand <i>Bordo carreggiata</i>	Überkopf <i>Sopra la carreggiata</i>	Tunnel <i>Galleria</i>	
Autobahnen, Autostrassen <i>Autostrade, semiautostrade</i>	R2 / R3	R2 / R3	R3 / I*	R2
Hauptstrasse, Nebenstrassen <i>Strade principali, strade secondarie</i>	R2	R2	R2 / R3	R1
Unbedeutende Nebenstrassen <i>Strade secondarie poco importanti</i>	R1	R1	R1	R1

Fett markiert = die empfohlene Anforderung, I* = innen ausgeleuchtete Signale
Stampato in grassetto = esigenza raccomandata, I = segnale illuminato all'interno*

Garanzia 3M

Wir fertigen Signale und grossflächige (Profil-)Tafeln nach den Vorgaben gemäss Garantievertrag der 3M (Schweiz) AG.



Fabbrichiamo segnaletica e cartelli (profilati) a grande superficie secondo le indicazioni del contratto di garanzia 3M (Svizzera) SA.

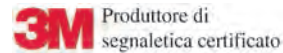

ISO 9001

Mit dem ganzheitlichen Managementsystem stellen wir sicher, dass unsere Produkte und Dienstleistungen konsequent den Qualitätsanforderungen der Kunden entsprechen und die Aspekte Sicherheit und Gesundheit konstant gelebt werden.

Grazie al sistema di gestione integrale, possiamo garantire che i prodotti e le prestazioni di servizio sono pienamente conformi alle esigenze di qualità della clientela e che gli aspetti sicurezza e salute sono costantemente considerati.

ISO 14001

Mit dem betrieblichen Umweltmanagementsystem (UMS) leisten wir einen Beitrag zur Schonung der Umwelt und zur Steigerung der Lebensqualität und stellen ein geordnetes Recycling von Abfällen sicher.

Grazie al sistema aziendale di gestione ambientale diamo un contributo alla protezione dell'ambiente e al miglioramento della qualità di vita e assicuriamo un riciclaggio adeguato dei rifiuti.

OHSAS 18001

OHSAS 18001 regelt seit 1999 die gültigen Kriterien für die Bewertung eines Arbeitssicherheits-Managementsystems. Mit der Erfüllung dieser Norm stellen wir sicher, dass unser sicherheitsgerechtes Verhalten in den Unternehmensprozessen integriert ist. Mit dem OHSAS 18001 Zertifikat erfüllen wir gleichzeitig auch die EKAS-Richtlinie 6508.

OHSAS 18001 dal 1999 definisce i criteri validi per la valutazione di un sistema di gestione a tutela della sicurezza sul lavoro. L'attuazione di tale norma ci consente di integrare la nostra condotta rispettosa della sicurezza nei processi aziendali. Con la certificazione OHSAS 18001 al tempo stesso sottostiamo anche alla direttiva della CFSL 6508.



Seite / pagina

Touristische Signalisation Segnaletica turistica	2	Hinweissignale / <i>Segnali indicatori</i>
	3	Wegweiser für den fließenden Verkehr / <i>Indicatori di direzione per il traffico in movimento</i>
	5	Wegweiser für Fussgänger / <i>Indicatori di direzione per pedoni</i>
	6	Hotelwegweisung / <i>Indicatori di direzione per alberghi</i>
	8	Symboltafeln / <i>Cartelli con simboli</i>
	9	Symbole nach VSS und individuell / <i>Simboli secondo VSS e individuali</i>
	11	Hinweistafeln / <i>Cartelli informativi</i>
	Signalisation Langsamverkehr Segnaletica traffico lento	12
17		Wegweiser für Wanderwege / <i>Segnali indicatori per sentieri</i>
Informationssysteme Sistemi d'informazione	18	Fussgänger-Leitsystem mit Signa CIS / <i>Sistema di guida per pedoni con Signa CIS</i>
	19	Fussgänger-Leitsystem mit Signa SCALA / <i>Sistema di guida per pedoni con Signa SCALA</i>
	20	Plakatwand Signa CLIP / <i>Pannelli d'affissione Signa CLIP</i>
Diverse Signale Segnali diversi	21	Spezielle Tafeln / <i>Cartelli speciali</i>
	21	Wappen / <i>Stemmi</i>
Strassennamenschilder Targhe per toponomastica	22	Strassennamenschilder / <i>Targhe per toponomastica</i>
	23	Hausnummernschilder / <i>Targhe per numeri civici</i>
Signalträger und Befestigungen Supporti per segnali e fissaggi	24	Befestigungen / <i>Sostegni</i>
	26	Signalträger / <i>Supporti per segnali</i>
	31	Halterungen / <i>Fissaggi</i>
	32	Rohrmasten / <i>Pali</i>
	33	Verankerungen / <i>Ancoraggi</i>

Touristische Signalisation

Segnaletica turistica

Hinweissignale

Segnali indicatori



4.79
Zeltplatz
Campeggio



4.80
Wohnwagenplatz
Terreno per veicoli
abitabili



4.85
Hotel-Motel
Albergo, Motel



4.86
Restaurant
Ristorante



4.87
Erfrischungen
Bar



4.88
Informationsstelle
Informazioni



4.89
Jugendherberge
Ostello

Diverse Beispiele
Diversi esempi



4.07T
Tunnel mit Namen
(Beispiel)
Galleria con nome
(esempio)

Bestellinformationen

Informazioni per l'ordine

Signal Formate (mm) <i>Grandezza segnali (mm)</i>	350 x 500 500 x 700 700 x 1000 900 x 1250 <small>(Standard: Radius/raggio R=30)</small>
Material, Beschichtung <i>Materiale e tipo di pellicole</i>	AS (Alu, R1) AH (Alu, R2)
Preisliste <i>Listino prezzi</i>	P5-1

Rahmen und Ständer

Telai e supporti

	Seite pagina		Seite pagina
Signaflex R54F (350x500, 500x700, 700x1000)	26	Signaflex R54FA (350x500, 500x700, 700x1000)	26
R382J Jordahlschienen/Binari Jordahl (350x500, 500x700, 700x1000, 900x1250)	30	R381C (350x500, 500x700, 700x1000, 900x1250)	29
R56 (500x700)	30		



Bezeichnung Flussübergang
(Beispiele)
Designazione di un fiume
(esempio)



Bezeichnung Tunnel
(Beispiele)
Designazione di una galleria
(esempio)



Bestellinformationen

Informazioni per l'ordine

Signal Formate (mm) <i>Grandezza segnali (mm)</i>	
Preise <i>Prezzi</i>	

Rahmen und Ständer

Telai e supporti

Signalträger =
Portasegnali =

Wegweiser für den fließenden Verkehr

Indicatori di direzione per il traffico in movimento

- 1-3 Normsymbole
- 1 Symbol und einzeilige Schrift
- zweizeilige Schrift

- 1-3 simboli secondo norme
- 1 simbolo e testo su 1 riga
- testo su 2 righe

TWW 1020x250 (Beispiele/esempi)



4.47



4.48



TWW 1300x250 (Beispiele/esempi)



TWW 1300x350 (Beispiele/esempi)





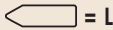

Bestellinformationen

Informazioni per l'ordine

Signal Formate (mm) Grandezza segnali (mm)	1020 x 250 1300 x 250 1300 x 350 <small>(Standard: Radius/raggio R=30)</small>
Beschriftung, Richtung Iscrizione, direzione	ES = Einseitig/1 lato DS = Beidseitig/doppio lato <small>Bei DS wird 1 x L und 1 x R geliefert/ Il DS è consegnato 1 x sinistra e 1 x destra</small>  = R  = L
Material, Beschichtung Materiale e tipo di pellicole	AS Alu, R1 weiss/schwarz oder braun/weiss <i>(bianco/nero o marrone/bianco)</i> AH Alu, R2 weiss/schwarz oder braun/weiss <i>(bianco/nero o marrone/bianco)</i>
Preisliste Listino prezzi	P5-2
Symbole Simboli	VSS individ. Seite/pagina 9 10

Rahmen und Ständer

Telai e supporti

	Seite pagina		Seite pagina
 Signaflex R71F	28	 R79J	30
 R78C	29	 R80C	29

Touristische Signalisation

Segnaletica turistica

Wegweiser für den fließenden Verkehr

Indicatori di direzione per il traffico movimento

- 1-3 Normsymbole
- 1 Symbol und einzeilige Schrift
- zweizeilige Schrift

- 1-3 simboli secondo norme
- 1 simbolo e testo su 1 riga
- testo su 2 righe

TWW 1020x250 (Beispiele/esempi)

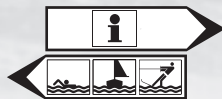

TWW 1300x250 (Beispiele/esempi)



TWW 1300x350 (Beispiele/esempi)





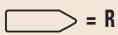
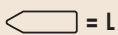

Bestellinformationen

Informazioni per l'ordine

Signal Formate (mm) <i>Grandezza segnali (mm)</i>	1020 x 250 1300 x 250 1300 x 350 <small>(Standard: Radius/raggio R=30)</small>
Beschriftung, Richtung <i>Iscrizione, direzione</i>	ES = Einseitig/1 lato DS* = Beidseitig/doppio lato * Bei DS wird 1 x L und 1 x R geliefert/ Il DS è consegnato 1 x sinistra e 1 x destra  = R  = L
Material, Beschichtung <i>Materiale e tipo di pellicole</i>	AS Alu, R1, weiss/schwarz oder braun/weiss (bianco/nero o marrone/bianco) AH Alu, R2 weiss/schwarz oder braun/weiss (bianco/nero o marrone/bianco)
Preisliste <i>Listino prezzi</i>	P5-2
Symbole <i>Simboli</i>	VSS individ. Seite/pagina 9 10

Rahmen und Ständer

Telai e supporti

	Seite pagina	Seite pagina	
 Signflex R271F	28	 Signflex R276F	28
 R78C	29	 R80C	29

Touristische Signalisation

Segnaletica turistica

Wegweiser für Fussgänger

Indicatori di direzione per pedoni

- 1-3 Normsymbole
- 1 Symbol und einzeilige Schrift
- zweizeilige Schrift

- 1-3 simboli secondo norme
- 1 simbolo e testo su 1 riga
- testo su 2 righe

Beispiele/esempi



Bestellinformationen

Informazioni per l'ordine

Signal Formate (mm) Grandezza segnali (mm)	F78, F78W, F74 * Tafeln aus Aluminium-Guss <i>Cartelli in alluminio pressofuso</i> 400 x 100
	FM78 ** Tafeln aus Alu-Hohlprofil (Merkel) <i>Cartelli in alluminio scatolato (Merkel)</i> 400 x 150 800 x 150 800 x 200
Beschriftung, Richtung Iscrizione, direzione	ES = Einseitig/1 lato DS = Beidseitig/doppio lato
	= R = L
Material, Beschichtung Materiale e tipo di pellicole	ALC* Allseitig weiss oder braun lackiert, Symbole Cal-Folie weiss/schwarz oder braun/weiss <i>Interamente verniciato bianco o marrone, simboli pellicola Cal bianco/nero o marrone/bianco</i> AS** Alu, R1, weiss/schwarz oder braun/weiss <i>(bianco/nero o marrone/bianco)</i>
Preisliste Listino prezzi	P5-3
Symbole Simboli	VSS individ. Seite/pagina 9 10

Befestigungen

Sostegni

Seite
pagina

	F78 * (400x100) Fahnenmässige Montage an Masten mit Stahlband oder Briden. <i>Montaggio a bandiera su pali con nastro in acciaio o bride.</i>	24
	F78W * (400x100) Analog F78, jedoch für die fahnenmässige Montage auf Wand. <i>Come F78, ma per montaggio a bandiera contro parete.</i>	24
	F74 * (400x100) Analog F78, jedoch zur Montage auf Wand. <i>Come F78, ma per montaggio contro parete.</i>	24
	FM78 ** → ST323 (400x150, 800x150, 800x200) Fahnenmässige Montage an Masten mit Briden (System Merkel). <i>Montaggio a bandiera su pali con bride (sistema Merkel).</i>	24
	FM78 ** → ST323 (400x150, 800x150, 800x200) Fahnenmässige Montage an Masten mit Stahlband (System Merkel). <i>Montaggio a bandiera su pali con nastro in acciaio (sistema Merkel).</i>	24
	FM78 ** → ST323W Alu-Befestigung für fahnenmässige Montage an Mauer (Merkel). <i>Sostegno in alluminio per montaggio a parete con viti</i>	24
	FM78 ** → ST348 Montage an Masten mit Befestigungsplatte und Briden (Merkel). <i>Montaggio su palo con placca di fissaggio e bride (Merkel).</i>	24
	FM78 ** → ST348TB Montage an Masten mit Befestigungsplatte und Stahlband (Merkel). <i>Montaggio su palo con placca di fissaggio e nastro in acciaio (Merkel).</i>	24
	FM78 ** → ST325W Wandmontage mit Schrauben. Pro Tafel 2 Stk. erforderlich. <i>Montaggio a parete con viti. Per cartello 2 pezzi necessari.</i>	24

Touristische Signalisation

Segnaletica turistica

Hotelwegweisung (Einzel-Wegweiser)

Indicatori di direzione per alberghi (indicatori singoli)



HWW

Einzel-Wegweiser/Indicatori singoli

	800x150
	1000x150
	1200x150

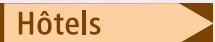

HWW

Sammel-Wegweiser/Indicatori generici

	800x150
	
	

Bestellinformationen

Informazioni per l'ordine

Signal Formate (mm) <i>Grandezza segnali (mm)</i>	Tafeln aus Alu-Hohlprofil (Merkel)/ <i>Cartelli in alluminio scatolato (Merkel)</i> Normalformat/formato normale 800 x 150 * 1000 x 150 1200 x 150 Die Länge richtet sich nach der Beschriftung <i>Lunghezza sec. numero di lettere</i>
Beschriftung, Richtung <i>Iscrizione, direzione</i>	ES = Einseitig/1 lato DS = Beidseitig/doppio lato  = R  = L
Material, Beschichtung <i>Materiale e tipo di pellicole</i>	AS Alu, R1
Preisliste <i>Listino prezzi</i>	P5-4

* Grösse für Sammelwegweiser
Grandezza per indicatori generici

Befestigungen

Sostegni

Seite
pagina

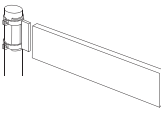
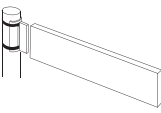
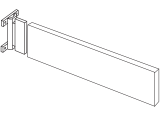
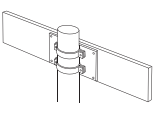
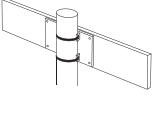
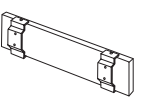
	ST323 Fahnenmässige Montage an Masten mit 2 Briden, Rohrmast Ø 60 mm <i>Montaggio a bandiera su pali con 2 bride,</i> <i>pali Ø 60 mm</i>	24
	ST323 Fahnenmässige Montage an Masten mit Stahlband, Rohrmasten ab Ø 60 mm <i>Montaggio a bandiera su pali con nastro in acciaio,</i> <i>pali a partire da Ø 60 mm</i>	24
	ST323W Alu-Befestigung für fahnenmässige Montage an Mauer <i>Sostegno in alluminio per montaggio a parete con viti</i>	24
	ST348 Montage an Masten mit Befestigungsplatte und 2 Briden (bitte Mast Ø angeben) <i>Montaggio su pali con placca di fissaggio e con 2 bride</i> <i>(indicare il Ø del palo)</i>	24
	ST348TB Montage an Masten mit Befestigungsplatte und Stahlband, Rohrmasten ab Ø 60 mm <i>Montaggio su pali con placca di fissaggio e nastro in acciaio,</i> <i>pali a partire da Ø 60 mm</i>	24
	T325W Wandmontage mit Schrauben. Pro Tafel 2 Stk. erforderlich. <i>Montaggio a parete con viti. Per cartello 2 pezzi necessari.</i>	24

Touristische Signalisation

Segnaletica turistica

Wegweiser zu mehreren Hotels

Indicatori di direzione per più alberghi

HWW

Normalfall/caso normale

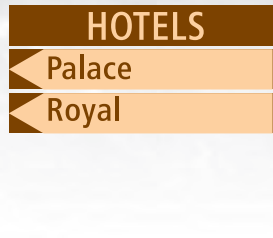

HWW

Bei ungünstigen Platzverhältnissen
Se il posto a disposizione è insufficiente



Bestellinformationen

Informazioni per l'ordine

Signal Formate (mm) Grandezza segnali (mm)	Tafeln aus Alu-Hohlprofil (Merkel)/ Cartelli in alluminio scatolato (Merkel)
	Normalformat/formato normale 800 x 150 1000 x 150 1200 x 150
	Die Länge richtet sich nach der Beschriftung Lunghezza sec. numero di lettere
Beschriftung, Richtung Iscrizione, direzione	ES = Einseitig/1 lato DS = Beidseitig/doppio lato
	= R = L
Material, Beschichtung Materiale e tipo di pellicole	AS Alu, R1
Preisliste Listino prezzi	P5-4

Befestigungen

Sostegni

Seite
pagina

	ST323 + WWK...* Fahnenmässige Montage an Masten mit Briden, Rohrmast Ø 60 mm, mit Sortiment Verbindungsstäben WWK Montaggio a bandiera su pali con bride, pali Ø 60 mm, con assortimento di barre d'assemblaggio WWK	25
	ST323 + WWK...* Fahnenmässige Montage an Masten mit Stahlband, Rohr- masten ab Ø 60 mm, mit Sortiment Verbindungsstäben WWK Montaggio a bandiera su pali con nastro in acciaio, pali a partire dal Ø 60 mm, con assortimento di barre d'assemblaggio WWK	25
	ST323W + WWK...* Alu-Befestigung für fahnenmässige Montage an Mauer mit Schrauben, mit Sortiment Verbindungsstäben WWK Sostegno in alluminio per montaggio a parete con viti e con assortimento di barre d'assemblaggio WWK	25
	ST348 + WWK...* Montage an Masten mit 2 Befestigungsplatten, 2 Briden und Sortiment Verbindungsstäbe WWK (5-7 Wegweiser: 3 Platten, 8-10 Wegweiser: 4 Platten) Montaggio su pali con 2 placche di fissaggio, 2 bride e assortimento di barre d'assemblaggio WWK (5-7 indicatori: 3 placche, 8-10 indicatori: 4 placche)	25
	ST348TB + WWK...* Montage an Masten mit 2 Befestigungsplatten und Stahlband (5-7 Wegweiser: 3 Platten, 8-10 Wegweiser: 4 Platten) Montaggio su pali con 2 placche di fissaggio con nastri d'acciaio (5-7 indicatori: 3 placche, 8-10 indicatori: 4 placche)	25

* Verbindungsstäbe WWK

Pro Kombination: 2 Stäbe, Arretierstücke, Distanzrondellen und Schrauben
Beispiel: WWK4 - Sortiment für Kombination von 4 Schildern (2 Stäbe, 6
Distanzrollen und 2 Schrauben).
Beispiel Art. Nr.: WWK4-150. Bitte immer Profilhöhe angeben.

* Barre di assemblaggio WWK

Per ogni combinazione: 2 barre, pezzo di arresto, distanziatori e viti incluse
Esempio: WWK4 - Assortimento per 4 indicatori (2 barre, 6 rondelle di
distanza e 2 viti).
Esempio Art. No: WWK4-150. P.f. indicare sempre altezza del profilato

Touristische Signalisation

Segnaletica turistica

Symboltafeln

Cartelli con simboli

Beispiel/esempio



Symboltafel 2000 x 1500 mm

- Tafel weiss/schwarz oder braun/weiss
- Ortsname in Astra-Frutiger oder Kursiv-Schrift
- Ortswappen (optional)
- 4 Symbole + Symbol "Informationsstelle" (400 x 320 mm)
- 1 Feld für Veranstaltungen (870 x 320 mm)

Cartello per simboli 2000x1500mm

- Cartello bianco/nero o marrone/bianco
- Nome della località con scrittura "Astra-Frutiger" o italia
- Stemma (opzione)
- 4 simboli + simbolo "Informazione" (400 x 320)
- 1 campo per le manifestazioni (870 x 320)

Bestellinformationen

Informazioni per l'ordine

Signal Formate (mm) Grandezza segnali (mm)	2000 x 1500 1500 x 1500 Ausrüstung mit Wechselschilder Equipaggiato con tabelle intercambiabili
Material, Beschichtung Materiale e tipo di pellicole	AS Alu, R1, weiss/schwarz oder braun/weiss (bianco/nero o marrone/bianco) AH Alu, R2 weiss/schwarz oder braun/weiss (bianco/nero o marrone/bianco)
Preisliste Listino prezzi	P5-5
Symbole Simboli	VSS Seite/pagina 9

Beispiel/esempio

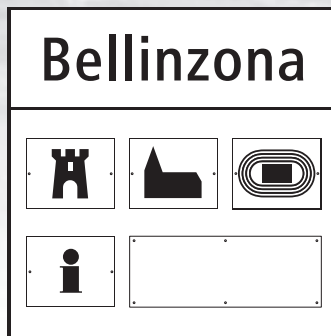

Symboltafel 1500 x 1500 mm

- Tafel weiss/schwarz oder braun/weiss
- Ortsname in Astra-Frutiger oder Kursiv-Schrift
- 3 Symbole + Symbol "Informationsstelle" (400 x 320 mm)
- 1 Feld für Veranstaltungen (870 x 320 mm)

Cartello per simboli 1500x1500mm

- Cartello bianco/nero o marrone/bianco
- Nome della località con scrittura "Astra-Frutiger" o italia
- 3 simboli + simbolo "Informazione" (400 x 320)
- 1 campo per le manifestazioni (870 x 320)

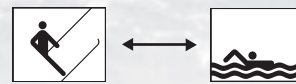

Die Symbole können einfach ausgetauscht werden, z.B. Umstellung Winter-Sommer
I simboli possono essere facilmente sostituiti, p.es. cambiamento inverno-estate

Rahmen und Ständer

Telai e supporti

	Seite pagina	Seite pagina	
R142VJ (1500x1500, 2000x1500) mit 2 Rohrmasten con 2 pali Empfohlene Rohrmasten: Pali consigliati: 1500x1500 → 2 x Ø 76 2000x1500 → 2 x Ø 89	30	* R142VJ (1500x1500, 2000x1500) mit 1 Rohrmast con 1 palo Empfohlene Rohrmasten: Pali consigliati: 1500x1500 → Ø 127*, Ø 133** 2000x1500 → Ø 140*, Ø 152**	30



Variante mit Fotografie in Digitaldrucktechnik auf Anfrage
Variante con fotografia a stampa digitale su richiesta

Touristische Signalisation

Segnaletica turistica

Symbole (VSS-Norm SN 640 827)
Simboli (norma VSS SN 640 827)



9.01
Bahnhof
Stazione



9.02
Bushof
Stazione stradale



9.05
Schiffstation
Stazione marittima



9.06
Zahnrad- o. Standseilbahn
Ferrovia a cremagliera o funicolare



9.07
Luftseilbahn
Teleferica



9.08
Gondelbahn
Telecabina



9.09
Sessellift
Seggiovia

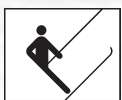

9.10
Skilift
Scilift



9.11
Sportflugplatz
Aerodromo per aerei da diporto



9.12
Schwimmbad
Piscina



9.13
Segelschule
Scuola di vela



9.14
Bootsvermietung
Affitto di barche



9.15
Wasserski
Sci nautico



9.16
Reiten
Equitazione



9.17
Fussballplatz
Campo di calcio



9.18
Tennisplatz
Campo da tennis



9.19
Golfplatz
Campo da golf

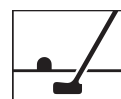

9.20
Miniaturgolf
Minigolf

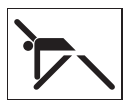

9.21
Fitnessparcours od. -platz
Percorso o piazza per fitness



9.22
Kinderspielplatz
Parcogiochi per bambini



9.23
Beaufsichtigter Kinderspielplatz / Parcogiochi per bambini sorvegliato



9.24
Eisbahn
Stadio del ghiaccio



9.25
Curling
Curling



9.26
Schlittelbahn
Pista per slitte



9.28
Skischule
Scuola di sci



9.29
Sprungschanze
Trampolino di lancio



9.30
Aussichtspunkt
Panorama



9.31
Sehenswerte Kirche
Chiesa da visitare



9.32
Burg, Ruine
Castello, rovine



9.33
Tiergarten, Zoo
Parco animali, zoo



9.34
Botanischer Garten
Giardino botanico



9.35
Naturlehrpfad
Sentiero didattico



9.36
Sportzentrum
Centro sportivo



9.37
Heilbad
Bagno termale



9.38
Campingplatz
Camping



9.39
Jugendherberge
Ostello della gioventù

Bestellinformationen

Informazioni per l'ordine

Signal Formate (mm)
Grandezza segnali (mm) 400 x 320 ind.

Material, Beschichtung
Materiale e tipo di pellicole

AS Alu, R1, weiss/schwarz oder weiss/braun (bianco/nero o bianco/marrone)
AH Alu, R2 weiss/schwarz oder weiss/braun (bianco/nero o bianco/marrone)

Preisliste
Listino prezzi

P5-6



9.42
WC
WC



9.43
Informationsstelle
Informazioni

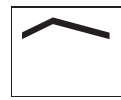

9...a
Hallen-
Coperto

Touristische Signalisation Segnaletica turistica

Individuelle Symbole Simboli individuali



9.01c



9.01d



9.40



9.45

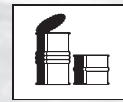

9.58



9.66



9.56



9.74



9.78



9.79b



9.88



9.91



9.118

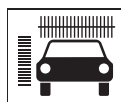

9.135



9.168

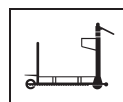

9.214



9.216



9.240



9.282



9.291



9.326



9.328



9.334



9.340

Bestellinformationen Informazioni per l'ordine

Signal Formate (mm)
Grandezza segnali (mm)



Preise
Prezzi



ind.

* Unsere Script-Abteilung verfügt über eine Vielzahl von weiteren Piktogrammen und Grafiken. Fragen Sie uns.

Il nostro settore Script, dispone di tanti altri pittogrammi e grafiche. Consultateci!

ind.*

Checkliste für Ihre individuellen Applikationen Check-list per le vostre applicazioni individuali

ind.

Information zu Logo und Grafik:

Damit von einem Logo, einer Grafik oder einem Bild ein exaktes Duplikat und nicht eine unbefriedigende Nachbildung gemacht werden kann, brauchen wir zwingend das richtige Dateiformat und einen „Originalausdruck“.

Bei Farbe sind zusätzlich die Farbangaben wie RAL, CMYK, oder Scotchcal farbtönen zu machen oder ein verbindlicher Farbausdruck mitzuliefern.

Information zu Schriften:

Schriften in einem Firmen-Logo sind normalerweise keine Schriften, sondern grafisch erarbeitete Zeichen und müssen als vektorisiertes Logo bzw. als Bestandteil des Logos angeliefert werden. Für Texte stehen einige hundert Schriften zur Verfügung. Hier benötigen wir von Ihnen die genaue Bezeichnung.

Was kann weiterverarbeitet werden:

Vektorformate für Logo und Grafiken zum Schneiden oder Siebdrucken: Adobe Illustrator (AI), Corel Draw (CDR), Encapsulated Post Script (EPS), AutoCAD und andere CAD (DXF), Windows Metafile (WMF)

Bild-Formate für Bilder zum Digitaldruck: PSD, TIFF, JPG (300 dpi)

Nicht brauchbare Formate: Microsoft Word (DOC), Microsoft Excel (XLS), Microsoft Power Point (PPS), Satzdateien wie Quark Xpress (QXD)

Informazioni su logo e grafica:

Onde permettere una replica esatta di un logo, una grafica o un'immagine ed evitare una riproduzione insoddisfacente, necessitiamo necessariamente di un formato dati adatto e una „stampa originale“.

Per i colori occorrono informazioni complementari, quali RAL, CMYK o tono Scotchcal, o di disporre di una stampa colore affidabile.

Informazioni sulle scritte:

Le scritte nel logo delle ditte usualmente non sono in caratteri di stampa, ma dei segni realizzati graficamente e devono essere messi a disposizione in forma di logo vettoriale, rispettivamente come parte integrante di logo vettoriale. Per i testi sono disponibili centinaia di caratteri, per cui dobbiamo ricevere da parte vostra la denominazione esatta.

Cosa può essere elaborato:

Formati vettoriali per logo e grafica da tagliare o serigrafare:

Adobe Illustrator (AI), Corel Draw (CDR), Encapsulated Post Script (EPS), AutoCAD et autres CAD (DXF), Windows Metafile (WMF)

Formati d'immagine per stampa digitale: PSD, TIFF, JPG (300 dpi)

Formati non utilizzabili: Microsoft Word (DOC), Microsoft Excel (XLS), Microsoft Power Point (PPS), dati di testo quali Quark Xpress (QXD)

Touristische Signalisation Segnaletica turistica

Hinweistafeln Cartelli informativi

Beispiele/Esempi



Beispiele im Digitaldruckverfahren (für Fotos)
Esempi in stampa digitale (per foto)



Bestellinformationen Informazioni per l'ordine

Signal Formate (mm) Grandezza segnali (mm)	
Material, Beschichtung Materiale e tipo di pellicole	AC Alu, CAL-Folie/pellicola CAL AS Alu, R1
Preise Prezzi	

Rahmen und Ständer Telai e supporti

	Seite pagina		Seite pagina
 R142VJ (1500x1500, 2000x1500) mit 2 Rohrmasten con 2 pali Empfohlene Rohrmasten: Pali consigliati: 1500x1500 → 2 x Ø 76 2000x1500 → 2 x Ø 89	30	 R142VJ (1500x1500, 2000x1500) mit 1 Rohrmast con 1 palo Empfohlene Rohrmasten: Pali consigliati: 1500x1500 → Ø 127*, Ø 133** 2000x1500 → Ø 140*, Ø 152**	30
 Alu-Profilbauweise Profilo in alluminio	30		

Signalisation Langsamverkehr

Segnaletica per traffico lento

Wegweiser für Velos, Mountainbikes und Fahrzeugähnliche Geräte (FäG)

Segnali per velocipedi e veicoli comparabili



V-4.50.1
Wegweiser "Route für Radfahrer"
mit Zielangaben (Beispiele h= 150 mm)
Indicatore di direzione "Itinerario per
ciclisti" con indicazione di destinazione

(600 x 150 max. 1200 x 150)

Beispiele mit Ziel- und Distanzangaben:
Esempi con indicazione di destinazione e distanza:



(600 x 200 max. 1200 x 200)

B-4.50.3
Wegweiser "Route für Mountainbikes"
mit Zielangaben (Beispiele h= 150 mm)
Indicatore di direzione "Itinerario per
mountain-bikes" con indicazione di
destinazione

(600 x 150 max. 1200 x 150)



(600 x 200 max. 1200 x 200)

S-4.50.4
Wegweiser "Route für Fahrzeugähnliche Geräte"
mit Zielangaben (Beispiele h= 150 mm)
Indicatore di direzione "Itinerario per veicoli compa-
rabili ai velocipedi" con indicazione di destinazione

(600 x 150 max. 1200 x 150)



(600 x 200 max. 1200 x 200)



Bestellinformationen

Informazioni per l'ordine

Signal Formate (mm) Grandezza segnali (mm)	Tafeln aus Alu-Hohlprofil (Merkel) Cartelli in alluminio scatolato (Merkel)													
	<table border="0"> <tr><td>600 x 150</td><td>600 x 200</td></tr> <tr><td>700 x 150</td><td>700 x 200</td></tr> <tr><td>800 x 150</td><td>800 x 200</td></tr> <tr><td>900 x 150</td><td>900 x 200</td></tr> <tr><td>1000 x 150</td><td>1000 x 200</td></tr> <tr><td>1100 x 150</td><td>1100 x 200</td></tr> <tr><td>1200 x 150</td><td>1200 x 200</td></tr> </table>	600 x 150	600 x 200	700 x 150	700 x 200	800 x 150	800 x 200	900 x 150	900 x 200	1000 x 150	1000 x 200	1100 x 150	1100 x 200	1200 x 150
600 x 150	600 x 200													
700 x 150	700 x 200													
800 x 150	800 x 200													
900 x 150	900 x 200													
1000 x 150	1000 x 200													
1100 x 150	1100 x 200													
1200 x 150	1200 x 200													
Beschriftung, Richtung Iscrizione, direzione	Tafeln aus Aluminium (2mm) und Rohrrahmen / Cartelli in alluminio (2mm) e telai													
	<table border="0"> <tr><td>1020 x 250 **</td></tr> <tr><td>1300 x 250 **</td></tr> </table> <p>(Standard: Radius/raggio R=30)</p>	1020 x 250 **	1300 x 250 **											
1020 x 250 **														
1300 x 250 **														
Material, Beschichtung Materiale e tipo di pellicole	Tafeln aus Aluminium (5mm) Spezialanfertigung / Cartelli in alluminio (5mm) in esecuzione speciale													
	<p>ALC Allseitig lackiert RAL 3003, mit Cal-Folie rubinrot/weiss Interamente verniciato RAL 3003, con pellicola CAL (rosso/bianco)</p> <p>AS **Alu, R1, rubinrot/weiss (rosso rubino/bianco)</p>													
Preisliste Listino prezzi	P5-7													

Befestigungen

Fixations

	ST323 Fahnenmässige Montage an Masten mit Briden (System Merkel). Montaggio a bandiera su pali con bride (sistema Merkel).	24
	ST323 Fahnenmässige Montage an Masten mit Stahlband (Merkel). Montaggio a bandiera su pali con nastro in acciaio (Merkel).	24
	ST348 Montage an Masten mit Befestigungsplatte und Briden (Merkel). Montaggio su pali con placca di fissaggio e bride (Merkel)	24
	ST348TB Montage an Masten mit Befestigungsplatte und Stahlband (Merkel). Montaggio su pali con placca di fissaggio e nastro in acciaio (Merkel).	24
	ST325W Wandmontage mit Schrauben. Pro Tafel 2 Stk. erforderlich. Montaggio a parete con viti. Per cartello 2 pezzi necessari.	24
	V80 Fahnenhalterung für Wand- und Bandbefestigung (Tafeln aus Aluminium, 5 mm) / Montaggio a bandiera con fissaggio a muro e a nastro (cartelli in alluminio 5 mm)	24

Rahmen und Ständer

Telai e supporti

	Signaflex R71F **	Seite pagina 28		R79J **	Seite pagina 30
	R78C **	29		R80C **	29

Interner Hinweis: Suchfunktion z.B. **VES-4.50.1%** **BES-4.50.3%** **SES-4.50.4%**
Int.: funzione di ricerca p.es **VDS-4.50.1%** **BDS-4.50.3%** **SDS-4.50.4%**

5
TOURISTISCHE SIGNALISATION UND STRASSENAMEN
SEGNALETICA TURISTICA E TOPONOMASTICA
SIGNAL

Signalisation Langsamverkehr

Segnaletica per traffico lento

Wegweiser für Velos, Mountainbikes und Fahrzeugähnliche Geräte (FäG)

Segnali per velocipedi e veicoli comparabili



V-4.51.1 (Pikto 5.31)
Wegweiser "Route für Radfahrer"
ohne Zielangabe (Beispiel, 300 x 150)
Indicatore di direzione "Itinerario per ciclisti" senza indicazione di destinazione (esempio, 300 x 150)



B-4.51.1 (Pikto 5.32)
Wegweiser "Route für Mountainbikes"
ohne Zielangabe (Beispiel, 300 x 150)
Indicatore di direzione "Itinerario per mountain-bikes" senza indicazione di destinazione (esempio, 300 x 150)



S-4.51.1 (Pikto 9.82b)
Wegweiser "Route für Fahrzeugähnliche Geräte"
ohne Zielangabe (Beispiel, 300 x 150)
Indicatore di direzione "Itinerario per veicoli comparabili ai velocipedi" con indicazione di destinazione (esempio, 300 x 150)

Beispiele / Esempi:



(425 x 150)



(575 x 150)



(615 x 150, mit Standortfeld / con indicazione di luogo)

Bestellinformationen

Informazioni per l'ordine

Signal Formate (mm) Grandezza segnali (mm)	Tafeln aus Aluminium (5 mm) <i>Cartelli in alluminio (5 mm)</i> 300 x 150 425 x 150 575 x 150 615 x 150
	Tafeln aus Alu-Hohlprofil (Merkel) <i>Spzialanfertigung</i> <i>Cartelli in alluminio scatolato (Merkel), in esecuzione speciale</i>
Beschriftung, Richtung Iscrizione, direzione	ES = Einseitig/1 lato DS = Beidseitig/doppio lato = R = L
Material, Beschichtung Materiale e tipo di pellicole	ALC Allseitig lackiert RAL 3003, mit Cal-Folie rubinrot/weiss <i>Interamente verniciato RAL 3003, con pellicola CAL (rosso/bianco)</i> AS Alu, R1, rubinrot/weiss <i>(rosso rubino/bianco)</i>
Preisliste Listino prezzi	P5-8

Befestigungen

Sostegni

Seite
pagina

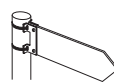

V78TB
Fahnenmässige Montage an Masten mittels Stahlband
(2 Stück sind erforderlich)
Montaggio a bandiera su pali con nastro in acciaio
(2 pezzi necessari)

24

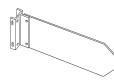

V80
Fahnenhalterung für Wand- und Bandbefestigung (Tafeln aus Aluminium, 5 mm) / *Montaggio a bandiera con fissaggio a muro e a nastro (cartelli in alluminio 5 mm)*

24

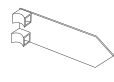

V79ALU
Montage an Masten mittels Stahlband
Montaggio su pali con nastro in acciaio

24

Interner Hinweis: Suchfunktion siehe Seite 12 unten
Int.: funzione di ricerca vedere pagina 12 in fondo

Signalisation Langsamverkehr Segnaletica per traffico lento

Signale für Velos, Mountainbikes und Fahrzeugähnliche Geräte (FäG) Segnali per velocipedi e veicoli comparabili



V-4.51.2
Vorwegweiser ohne Zielangabe
(Beispiel, 200 x 400)
Indicatore di direzione avanzato senza indicazione di destinazione (esempio, 200 x 400)



B-4.51.2
Vorwegweiser ohne Zielangabe
(Beispiel, 200 x 400)
Indicatore di direzione avanzato senza indicazione di destinazione (esempio, 200 x 400)



S-4.51.2
Vorwegweiser ohne Zielangabe
(Beispiel, 200 x 400)
Indicatore di direzione avanzato senza indicazione di destinazione (esempio, 200 x 400)



Weitere Beispiele 200 x 400 / Altri esempi 200 x 400



V-4.51.3
Bestätigungstafel
(Beispiel, 200 x 200)
Cartello di conferma (esempio, 200 x 200)



B-4.51.3
Bestätigungstafel
(Beispiel, 200 x 200)
Cartello di conferma (esempio, 200 x 200)



S-4.51.3
Bestätigungstafel
(Beispiel, 200 x 200)
Cartello di conferma (esempio, 200 x 200)



V-4.51.4
Endtafel
(200 x 200)
Cartello finale (200 x 200)



B-4.51.4
Endtafel
(200 x 200)
Cartello finale (200 x 200)



S-4.51.4
Endtafel
(200 x 200)
Cartello finale (200 x 200)



V-4.51S
Steigungs- und Gefälltafel (400 x 400)
Cartello di denivelazione (400 x 400)

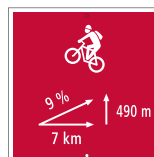

B-4.51S
Steigungs- und Gefälltafel (400 x 400)
Cartello di denivelazione (400 x 400)



S-4.51S
Steigungs- und Gefälltafel (400 x 400)
Cartello di denivelazione (400 x 400)

Bestellinformationen Informazioni per l'ordine

Signal Formate (mm)
Grandezza segnali (mm)

Tafeln aus Aluminium (5 mm)
Cartelli in alluminio (5 mm)
200 x 200
200 x 400
400 x 400

Tafeln aus Aluminium (2mm)
mit Rohrrahmen / *Cartelli in alluminio (2 mm) con telai*
200 x 200

Material, Beschichtung
Materiale e tipo di pellicole

ALC Allseitig lackiert RAL 3003, mit Cal-Folie rubinrot/weiss
Interamente verniciato RAL 3003, con pellicola CAL (rosso/bianco)
AS Alu, R1, rubinrot/weiss
(rosso rubino/bianco)

Preisliste
Listino prezzi

P5-9

Befestigungen Sostegni

Seite
pagina

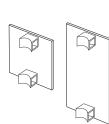

V79ALU
Montage an Masten mittels Stahlband
Montaggio su pali con nastri in acciaio

24

Rahmen und Ständer Telai e supporti

Seite
pagina



R362J
Jordahlschienen/Binari Jordahl
(200)

30

Interner Hinweis: Suchfunktion siehe Seite 12 unten
Int.: funzione di ricerca vedere pagina 12 in fondo

Signalisation Langsamverkehr

Segnaletica per traffico lento

Tabellarische Wegweiser für Velos, Mountainbikes und Fahrzeugähnliche Geräte (FäG)

Segnali per velocipedi e veicoli comparabili



V-4.50.5
Wegweiser in Tabellenform für einen einzigen Adressatenkreis (Beispiel, h = 700)
Indicatore di direzione a forma di tabella (esempio, h = 700)

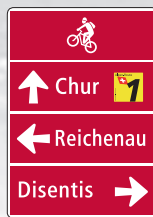

B-4.50.5
Wegweiser in Tabellenform für einen einzigen Adressatenkreis (Beispiel, h = 700)
Indicatore di direzione a forma di tabella (esempio, h = 700)

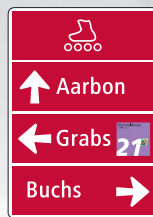

S-4.50.5
Wegweiser in Tabellenform für einen einzigen Adressatenkreis (Beispiel, h = 700)
Indicatore di direzione a forma di tabella (esempio, h = 700)

Weitere Beispiele:
Altri esempi:



V-4.50.5
Wegweiser in Tabellenform für einen einzigen Adressatenkreis (Beispiel, h = 700)
Indicatore di direzione a forma di tabella (esempio, h = 700)



V-4.50.5
Wegweiser in Tabellenform mit VSS-Symbolen (Beispiel)
Indicatore di direzione a forma di tabella combinato con simboli VSS (esempio)



VBS-4.50.6
Wegweiser in Tabellenform für mehrere Adressatenkreise (Beispiel, h = 500 mm)
Indicatore di direzione a forma di tabella (esempio, h = 500)



VBS-4.50.E
Entfernungstafel in Tabellenform für mehrere Adressatenkreise (Beispiel, h = 500 mm)
Cartello delle distanze a forma di tabella (esempio, h = 500 mm)



Gefahrensignal (Beispiel)
Segnale di pericolo (esempio)



2.61, Ende Velo gestattet (Beispiel)
2.61, Fine bici autorizzata (esempio)

Bestellinformationen

Informazioni per l'ordine

Signal Formate (mm) <i>Grandezza segnali (mm)</i>	<input type="checkbox"/> 500 x 700 <input type="checkbox"/> 700 x 1000 <input type="checkbox"/> ind. <input type="checkbox"/> 700 x 500 <input type="checkbox"/> 1000 x 700 <input type="checkbox"/> ind. (Standard: Radius/raggio R=30)	<input type="checkbox"/> 500 <input type="checkbox"/> 700
Material, Beschichtung <i>Materiale e tipo di pellicole</i>	ALC Allseitig lackiert RAL 3003, mit Cal-Folie rubinrot/weiss Interamente verniciato RAL 3003, con pellicola CAL (rosso/bianco) AS Alu, R1, rubinrot/weiss (rosso rubino/bianco)	
Preisliste <i>Listino prezzi</i>	P5-10	

Rahmen und Ständer

Telai e supporti

	Seite <i>pagina</i>		Seite <i>pagina</i>
Signaflex R54F (500x700, 700 x 1000)	26	Signaflex R54FA (500x700, 700 x 1000)	26
R382J Jordahlschienen/Binari Jordahl (500x700, 700 x 1000)	30	R381C (500x700, 700 x 1000)	29
R56 (500x700)	26	R55 (500)	26
Signaflex R53F (500, 700)	26	Signaflex R53FA (500, 700)	26
R362J Jordahlschienen/Binari Jordahl (500, 700)	30	R361C (500, 700)	29
Signaflex R64F (700x500, 1000x700)	27	Signaflex R64FA (700x500, 1000x700)	27
R392J Jordahlschienen/Binari Jordahl (700x500, 1000x700)	30	R391C (700x500, 1000x700)	29

Signalisation Langsamverkehr Segnaletica per traffico lento

Informationstafeln, "InfoPoint" Veloland Schweiz Cartelli informativi, "InfoPoint" La Svizzera in bici



VBS 4.88
Kennzeichnung des Standorts
(350)
Indicazione di luogo
(350)



Informationstafel
(700 x 1000)
Cartello informativo
(700 x 1000)



Beispiel eines "InfoPoints" mit Wegweisung und Zusatztafel
Esempio di un "InfoPoint" con indicazione di direzione e cartello addizionale

Bestellinformationen Informazioni per l'ordine

Signal Formate (mm) <i>Grandezza segnali (mm)</i>	<input type="checkbox"/> 350	<input type="checkbox"/> 700 x 1000
	(Standard: Radius/raggio R=30)	
Material, Beschichtung <i>Materiale e tipo di pellicole</i>	AC mit Cal-Folie und UV-Schutzlack con pellicola CAL e protezione UV	
Preisliste <i>Listino prezzi</i>		

Rahmen und Ständer Telai e supporti

	Seite pagina		Seite pagina
Signflex R53F (350)	26	R382J Jordahlschienen/Binari Jordahl (700x1000)	30

Touristische und alpine Informationstafeln Cartelli informativi turistici e alpini



Touristische Informationstafel
(Beispiel, 210 x 148 mm)
Cartello informativo turistico
(esempio, 210 x 148 mm)

Informationstafel Alpinwanderweg
(Beispiel, 210 x 297 mm)
Cartello informativo per escursioni alpine
(esempio, 210 x 148 mm)

Bestellinformationen Informazioni per l'ordine

Signal Formate (mm) <i>Grandezza segnali (mm)</i>	Tafeln aus Aluminium (5 mm) <i>Cartelli in alluminio (5 mm)</i>
<input type="checkbox"/> 210 x 148	<input type="checkbox"/> 210 x 297
Material, Beschichtung <i>Materiale e tipo di pellicole</i>	AC mit Cal-Folie und UV-Schutzlack con pellicola CAL e protezione UV
Preisliste <i>Listino prezzi</i>	

Befestigungen Supporti

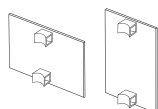

V79ALU
Montage an Masten mittels Stahlband
Montaggio su pali con nastro in acciaio

Seite
pagina

24

Signalisation Langsamverkehr

Segnaletica per traffico lento

Wegweiser für Wanderwege

Segnali indicatori per escursioni

Wegweiser für Wanderwege (Beispiele)
Segnali indicatori per escursioni (esempi)

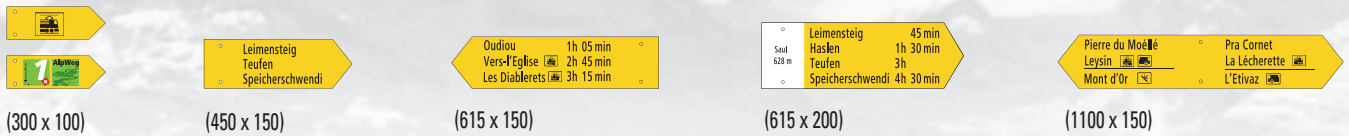

Wegweiser für Bergwanderwege (Beispiele)
Segnali indicatori per escursioni in montagna (esempi)



Kombinierte Wegweiser für Wander- und Bergwanderwege (Beispiele)
Segnali indicatori combinati per escursioni e escursioni in montagna (esempi)



Wegweiser für Alpinwanderwege (Beispiele)
Segnali indicatori per escursioni alpine (esempi)



Bestellinformationen

Informazioni per l'ordine

Signal Formate (mm) <i>Grandezza segnali (mm)</i>	Tafeln aus Aluminium (5mm) <i>Cartelli in alluminio (5 mm)</i>	Typen, Beschriftung, Richtung <i>Tipi, Iscrizione, direzione</i>	Typen/Tipi:
	Wegweiser ohne Zeitangaben <i>Indicatori senza tempo di marcia</i>		- Wanderweg/ <i>Escursioni</i> - Bergwanderweg/ <i>Escursioni in montagna</i> - Alpiner Wanderweg/ <i>Escursioni alpine</i> - Wanderweg und Bergwanderweg kombiniert/ <i>Escursioni e escursioni in montagna combinate</i> - mit oder ohne Zeitangaben / <i>con o senza tempo di marcia</i> - mit oder ohne Stadortfeld / <i>con o senza indicazione della posizione</i>
	450 x 120 450 x 150 450 x 200		- Optional: VSS-Symbole <i>Opzione: simboli VSS</i>
	800 x 120 800 x 150 800 x 200		Beschriftung/Iscrizione:
	Wegweiser mit Zeitangaben <i>Indicatori con tempo di marcia</i>		ES = Einseitig/ <i>1 lato</i> DS = Beidseitig/ <i>doppio lato</i>
	615 x 120 615 x 150 615 x 200		= R = L
	1100 x 120 1100 x 150 1100 x 200		
	Wegweiser ohne Zielangabe <i>Indicatori senza destinazioni</i>		
	300 x 100 350 x 100		
Material, Beschichtung <i>Materiale e tipo di pellicole</i>	ALD Allseitig lackiert RAL 1007, inkl. Text und UV-Schutzlack/ <i>Interamente verniciato RAL 1007, testo incl. e protezione UV</i>	Befestigung <i>Supporto</i>	Seite <i>pagina</i>
Preisliste <i>Listino prezzi</i>	P5-13	V79ALU Montage an Masten mittels Stahlband <i>Montaggio su pali con nastri in acciaio</i>	24

Interner Hinweis: Suchfunktion z.B. WA%, gilt nur für Wander- und Bergwanderwege
Int.: funzione di ricerca p.es. WA%, valido solo per vie pedestri e di montagna

Informationssysteme Sistemi d'informazione

Fussgänger-Leitsystem mit Signa CIS Sistema di guida per pedoni con Signa CIS

- **modernes Design** - als Basis für grosse Gestaltungsfreiheit
- **modularer Aufbau** - für vielfältige Konstruktionslösungen
- **top Preis-Leistungsverhältnis** - durch riesige Auswahl an Systemkomponenten
- **nachhaltige Nutzung** - dank leicht austauschbaren Elementen
- **Desing moderno:** Come base per una grande libertà di configurazione
- **Struttura modulare:** per soluzioni costruttive variate
- **Rapporto prezzo-prestazione ottimale:** grazie a una grande scelta delle componenti del sistema
- **Di lunga durata:** grazie agli elementi facilmente sostituibili



Wechselmodul zur Aufnahme von laminierten Papierinformationen für den schnellen Austausch
Modulo intercambiabile come supporto d'informazione su foglio plastificato per un cambio rapido



Bestellinformationen Informazioni per l'ordine

Signal Formate (mm)
Grandezza segnali (mm)



Preise
Prezzi



5
TOURISTISCHE SIGNALISATION UND STRASSENAMEN
SEGNALETICA TURISTICA E TOPONOMASTICA



Weitere Produkte und Beispiele siehe
Kapitel 6 - Informationssysteme
Altri prodotti ed esempi, vedi
capitolo 6 - Sistemi d'informazione

Fussgänger-Leitsystem mit Signa SCALA Sistema di guida per pedoni con Signa SCALA

- **Konkave Form des Umrundungsprofils** - verleiht diesem Leit- und Orientierungssystem eine erfrischend professionelle Note
 - **Kundenspezifische Masse, individuelle Farbwahl sowie hohe Verfügbarkeit** von Einzelteilen dank eigener Fabrikation
 - **Beschriftungstafel in einem Stück** über die gesamte Stelenhöhe oder unterteilt in einzelne Tafeln wählbar
 - **Schutz vor Vandalismus**, da keine Schrauben und Befestigungsteile sichtbar sind
 - **Gestaltungsfreiheit** dank Kombination von Klebtechnik und Digitaldruck
- **Forma concava del profilato della cornice** conferisce a questo sistema di guida e orientamento un innovativo tocco professionale
 - **Dimensioni personalizzate, selezione individuale dei colori ed elevata disponibilità** delle singole componenti grazie alla duttilità della nostra produzione
 - **Pannello in un pezzo unico** su tutta l'altezza del totem o suddivisione in pannelli singoli, a scelta
 - **Protezione antivandalismo**, nessuna vite o parte di fissaggio a vista
 - **Libertà esecutiva grazie** alla combinazione tra tecnica d'incollaggio e stampa digitale

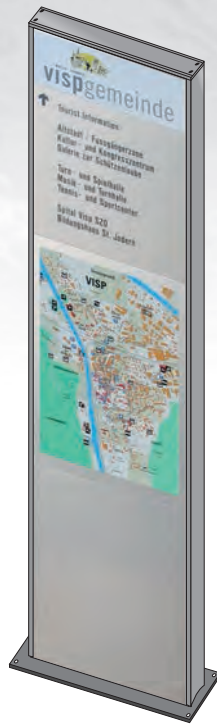

Variante 1
Beschriftungstafel
Boden bündig
Pannello fino al suolo



Variante 2
Beschriftungstafel unten
mit Freiraum
Pannello con spazio libero
in basso

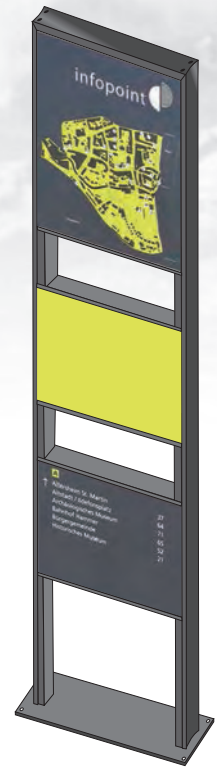

Variante 3
Beschriftungselemente mit
mehreren Freiräumen
Elementi con più spazi liberi

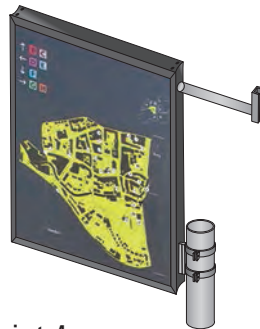

Variante 4
Panel als Fahnen- und
Wandmontage mit verschie-
denen seitlichen Befestigungs-
möglichkeiten
Pannello per montaggio a bandiera
o a muro con diverse possibilità
di fissaggio laterale

Verschiedene Varianten für
Stelen-Einsätze möglich:

- Alu-, Forex-, Plexiglastafel
- LED-Display
- Ausgeleuchtete Tafel

Diverse possibilità di inseri-
mento di elementi nei totem:

- Pannello in alluminio, Forex,
plexiglas
- Schermo LED
- Pannello illuminato

Weitere Produkte und Beispiele siehe
Kapitel 6 - Informationssysteme
Altri prodotti ed esempi, vedi
capitolo 6 - Sistemi d'informazione

Bestellinformationen Informazioni per l'ordine

Signal Formate (mm) Grandezza segnali (mm)	
Preise Prezzi	

Plakatwand Signa CLIP
Pannelli di affissione Signa Clip



WR 03.433 ASEN*
905 x 1280 mm



WR CLIP (905 x 1280 mm)
WRCNO ... WRCN710
(841 x 1189 mm ... 700 x 1000 mm)



WR 15.310 KUST (700 x 1000 mm)
WR 15.491 KUST (905 x 1280 mm)

Profile 20/25/32/44 mm
Profili 20/25/32/44 mm

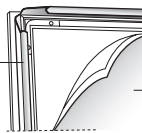

ARF 905
PVC Anti-Reflex-Schutzfolie, 0,5 - 08 mm, UV beständig
Foglio protettivo anti-riflesso in materiale PVC resistente
ai raggi UV, 0,5 - 08 mm

Bestellinformationen
Informazioni per l'ordine

Typen Tipi	Art.-Nr. No. dell'articolo	Format Formato	Papierformat, b x h (mm) Grandezza del foglio, l x a	Profil
WR 03.433 ASEN*	F4	905 x 1280	44	Aluminium-Rahmen natureloxiert, mit Alu-Rückwand 1,5 mm, Wasserdicht, inkl. 2 Profilschienen für Montage mittels Briden oder Stahlband, Front mit Anti-Reflex-Schutzfolie Telaio in alluminio, elox-naturale, resistente all'acqua, incl. 2 binari per montaggio con bride o nastro in acciaio. Copertura in materiale PVC antiriflesso
WR 15.491 KUST	F4	905 x 1280	44	Aluminium-Rahmen natureloxiert, mit Spitzecken 90° und Stahl-Rückwand 1,5 mm, montiert auf Klappständer, doppelseitig Telaio in alluminio, elox-naturale, con parete posteriore in acciaio 1.5 mm, montato su supporto pieghevole, doppio lato
WR 15.310 KUST	ind.	700 x 1000	32	Aluminium-Rahmen natureloxiert, mit Rundecken und Stahl-Rückwand 1,5 mm, montiert auf Klappständer, doppelseitig Telaio in alluminio, elox-naturale, con parete posteriore in acciaio 1.5 mm, montato su supporto pieghevole, doppio lato
WR CLIP	F4	905 x 1280	44	
WRCNO	A0	841 x 1189	32	
WRCN1	A1	594 x 841	32	
WRCN2	A2	420 x 594	32	
WRCN3	A3	297 x 420	32	
WRCN4	A4	210 x 297	32	
WRCN57	ind.	500 x 700	32	
WRCN710	ind.	700 x 1000	32	

wie WR 03.433 ASEN, jedoch ohne Profilschienen
come WR 03.433 ASEN, ma senza binari

ZT19.028
Rahmenöffner aus Kunststoff/Apritelao in plastica.

ARF 905
Anti-Reflex-Schutzfolie zu WR CLIP, Format = 927x1302
Foglio protettivo antiriflesso per WR Clip

Preisliste
Listino prezzi

P5-14

Briden, Rohrmasten und Verankerung
Bride, pali e ancoraggi

* 2 Briden, Rohrmast und Betonfundament
2 bride, palo e fondazione in cemento

Rohrmast Ø 60 mm, Länge 2400 mm feuerverzinkt, passend zu Betonfundament EV 700 BE, 2 Briden Ø 60 mm aus Aluminium
Palo Ø 60 mm, lunghezza 2400 mm zincato, per fondazione EV 700 BE, 2 bride Ø 60 mm in alluminio

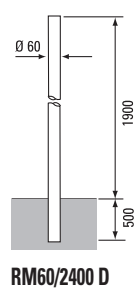

* BR 60 ALU Alu-Bride/Brida in alluminio Ø 60 mm
BR 76 ALU Alu-Bride/Brida in alluminio Ø 76 mm
BR 90 ALU Alu-Bride/Brida in alluminio Ø 90 mm



* 2 Briden, Rohrmast und Betonsockel
2 bride, palo e base in cemento

Rohrmast Ø 33 mm, feuerverzinkt, passend zu Betonsockel BE35, BE67, BE80
2 Briden Ø 33 mm aus Aluminium
Palo Ø 33 mm, zincato, per base in cemento BE35, BE67, BE80, 2 bride Ø 33 mm in alluminio

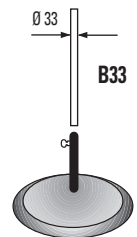

* BR 33 FV Bride feuerverzinkt/Brida zincata Ø 33 mm



Preisliste
Listino prezzi

P5-14

Rohrmasten
Pali

Seite
pagina 32, 33

Verankerung
Ancoraggi

Seite
pagina 33

Diverse Schilder, Wappen und Hausnummern Diversi segnali, stemmi e targhe dei numeri civici

Spezielle Tafeln Tavole speciali



4.33F
Ferien auf dem Bauernhof
Vacanze in fattoria



Ferien auf dem Bauernhof
Vacanze in fattoria



LAW 600x700 AS
Lawinengefahr
Pericolo di valanghe



1.30SW420x770xAS
Schwallwasser
Ondate improvise

Unsere Fachberater informieren Sie gerne über weitere Anwendungsmöglichkeiten rund um das Thema Touristik.

I nostri consulenti vi informano volentieri sulle numerose possibilità sul tema turismo.

Bestellinformationen Informazioni per l'ordine

Signal Formate (mm) Grandezza segnali (mm)	
Preise Prezzi	

Wappen Stemmi



Beispiele esempi

Wappen aus wetterfester Selbstklebefolie. Größen (Standardgröße 250 mm), Formen und Farben nach Ihren Wünschen.

Stemmi su foglio adesivo resistente alle intemperie. Grandezza (altezza standard 250 mm), forma e colore secondo vostri desideri.

Bestellinformationen Informazioni per l'ordine

Signal (mm) Dimensioni (mm)	210 x 250 * ind.
Preise Prezzi	

* Passend zu touristischen Symboltafeln (Seite 8)
Per cartelli con simboli turistici (pagina 8)

Strassennamenschilder Targhe per toponomastica

Strassennamenschilder in Aluminium-Hohlprofil Targhe per toponomastica con profilo in alluminio scatolato

MT

Schulhausstrasse



Zentralstrasse

25 38

Poststrasse 34

Lindenweg

Kongresshalle

SMUV Tagung

ZUSATZSCHILD/TARGA SUPPLEMENTARE

Zusatzschild zum
Einschieben, z.B. für
temporäre Informationen
Targa supplementare,
scorrevole, p. es. per
informazioni temporanee

Bestellinformationen Informazioni per l'ordine

Signal Formate (mm)
Grandezza segnali (mm)

Tafeln aus Alu-Hohlprofil (Merkel)/
Cartelli in alluminio scatolato (Merkel)

Normalformat/
Formato normale

Anz. Buchstaben, ca./
Numero di lettere, ca.

400 x 150	6
500 x 150	8
600 x 150	11
700 x 150	13
800 x 150	15
900 x 150	17
1000 x 150	19

Grossformat/
Grande formato

Anz. Buchstaben, ca./
Numero di lettere, ca.

400 x 200	4
500 x 200	6
600 x 200	9
700 x 200	11
800 x 200	13
900 x 200	15
1000 x 200	17

Zusatzschild/
Targa suppl.

Anz. Buchstaben, ca./
Numero di lettere, ca.

150 x 63	5
300 x 63	11
400 x 63	15

Beschriftung
Iscrizione

ES = Einseitig/1 lato
DS = Beidseitig/doppio lato

Material, Beschichtung
Materiale e tipo di
pellicole

ALC	Allseitig lackiert, mit Cal-Folie Interamente verniciato, con pellicola CAL
AS	Alu, R1
ASC	Alu, reflektierend, Schrift Cal-Folie Alu, riflettente, lettere con pellicola CAL
AH	Alu, R2

Preisliste
Listino prezzi

P5-15

Befestigungen Sostegni

Seite
pagina

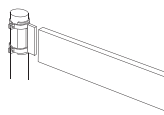

ST323
Fahnenmässige Montage an Masten mit 2 Briden,
Rohrmast Ø 60 mm
Montaggio a bandiera su pali con 2 bride,
pali Ø 60 mm

24

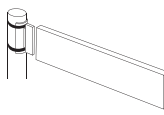

ST323
Fahnenmässige Montage an Masten mit Stahlband,
Rohrmasten ab Ø 60 mm
Montaggio a bandiera su pali con nastro in acciaio,
pali a partire da Ø 60 mm

24

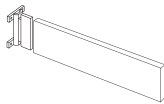

ST323W
Alu-Befestigung für fahnenmässige Montage an Mauer
Sostegno in alluminio per montaggio a parete con viti

24

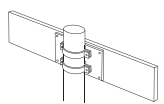

ST348
Montage an Masten mit Befestigungsplatte und 2 Briden
(bitte Mast Ø angeben)
Montaggio su pali con placca di fissaggio e con 2 bride
(indicare il Ø del palo)

24

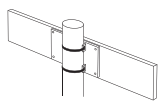

ST348TB
Montage an Masten mit Befestigungsplatte und Stahlband,
Rohrmasten ab Ø 60 mm
Montaggio su pali con placca di fissaggio e nastro in acciaio,
pali a partire da Ø 60 mm

24

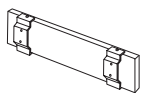

T325W
Wandmontage mit Schrauben. Pro Tafel 2 Stk. erforderlich.
Montaggio a parete con viti. Per cartello 2 pezzi necessari.

24

Strassennamenschilder Targhe per toponomastica

Strassennamenschilder aus Aluminiumguss Targhe per toponomastica in alluminio pressofuso

STR AG

Bahnhofstrasse

Bestellinformationen Informazioni per l'ordine

Signal Formate (mm) <i>Grandezza segnali (mm)</i>	STR AG ... x 150* ... x 250* * Länge richtet sich nach der Anzahl der Buchstaben <i>Lunghezza sec. numero di lettere</i>
Material, Beschichtung <i>Materiale e tipo di pellicole</i>	Aluminiumguss Lackiert, Schrift und Rand erhoben (bitte RAL-Farbe angeben) <i>Alluminio pressofuso verniciato, lettere e bordo in rilievo (indicare colore RAL)</i>
Preisliste <i>Listino prezzi</i>	P5-17

Befestigungen Sostegni

Seite
page

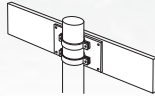
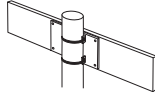
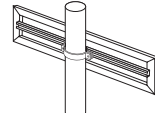
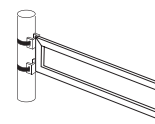
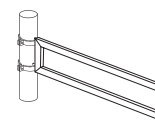
	ST348 Montage an Masten mit Befestigungsplatte und 2 Briden (bitte Mast Ø angeben) <i>Montaggio su pali con placca di fissaggio e con 2 bride (indicare il Ø del palo)</i>	24
	ST348TB Montage an Masten mit Befestigungsplatte und Stahlband, Rohrmasten ab Ø 60 mm <i>Montaggio su pali con placca di fissaggio e nastro in acciaio, pali a partire da Ø 60 mm</i>	24
	R143VJ Träger mit Jordahlschiene, Montage mit Briden <i>Fissaggio con sistema "Jordal", montaggio con bride</i>	25
	R143VC Fahnenmässige Montage an Masten mit Vierkantrahmen und Stahlband, Rohrmasten ab Ø 60 mm <i>Montaggio a bandiera su pali con telaio quadro e nastro in acciaio, pali a partire da Ø 60 mm</i>	25
	R143V Fahnenmässige Montage an Masten mit Briden, Rohrmasten ab Ø 60 mm <i>Montaggio a bandiera su pali con bride, pali a partire da Ø 60 mm</i>	25

Hausnummernschilder aus Aluminium 2mm Targhe dei numeri civici in alluminio 2 mm

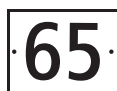

Bestellinformationen Informazioni per l'ordine

Formate (mm) <i>Formato (mm)</i>	160 x 120 ind.
Material, Beschichtung <i>Materiale e tipo di pellicole</i>	HAS Grund und Schrift reflektierend <i>Fondo e scritta riflettenti</i>
Preisliste <i>Listino prezzi</i>	P5-18

Hausnummernschilder aus Aluminiumguss Targhe dei numeri civici in alluminio pressofuso



Bestellinformationen Informazioni per l'ordine

Formate (mm) <i>Formato (mm)</i>	155 x 95 220 x 95 ind.
Material, Beschichtung <i>Materiale e tipo di pellicole</i>	HAG Aluminiumguss RAL.../Alu (bitte RAL-Farbe angeben) <i>Alluminio pressofuso RAL.../Alu, (indicare colore RAL)</i>
Preisliste <i>Listino prezzi</i>	P5-19

5

TOURISTISCHE SIGNALISATION UND STRASSENAMEN
SEGNALETICA TURISTICA E TOPONOMASTICA

SIGNAL

Befestigungen Sostegni

Befestigungen für Tafeln aus Aluminiumguss oder 5 mm Sostegni per targhe in alluminio pressofuso o 5 mm

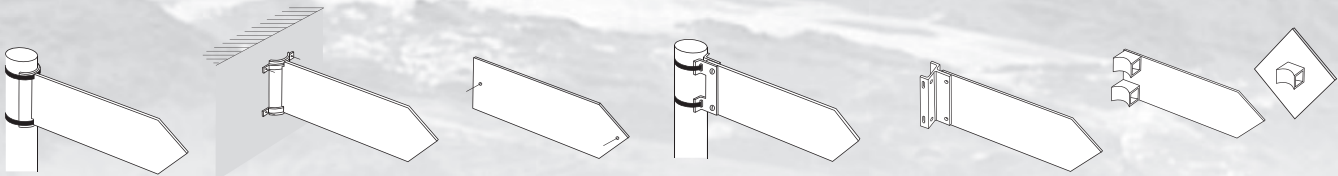

Fahnenmässige Montage von F78 an Masten mittels Stahlband oder Briden
Montaggio a bandiera di F78 su pali con nastro in acciaio

Fahnenmässige Montage von F78W an Wand mittels Briden
Montaggio a bandiera di F78W a parete con bride

Montage von F74 auf Wand.
Montaggio di F74 a parete

V78TB
Fahnenhalterung feuerverzinkt für Bandbefestigung inkl. Becherkopfschrauben M6x16 mm, 2 Stück sind erforderlich
Sostegno zincato a bandiera per montaggio con nastro in acciaio, incluso bulloni M6x16mm, 2 pezzi necessari

V80
Fahnenhalterung für Wand- und Bandbefestigung (Tafeln aus Aluminium, 5 mm)
Montaggio a bandiera con fissaggio a muro e a nastro (cartelli in alluminio 5 mm)

V79ALU
Alu-Bügel für Bandbefestigung inkl. Becherkopfschrauben M8x16 mm.
Staffa per montaggio con nastro in acciaio, incl. bulloni M8x16

V78TB 150 h/a = 150
V78TB 200 h/a = 200

V80 100 h = 100
V80 200 h = 200

Befestigungsmaterial
Materiale per fissaggio

31

31

31

Preisliste
Listino prezzi

P5-21

P5-21

P5-22

Befestigungen für Tafeln aus Alu-Holprofil (Merkel) Sostegni per targhe in alluminio scatoletto (Merkel)

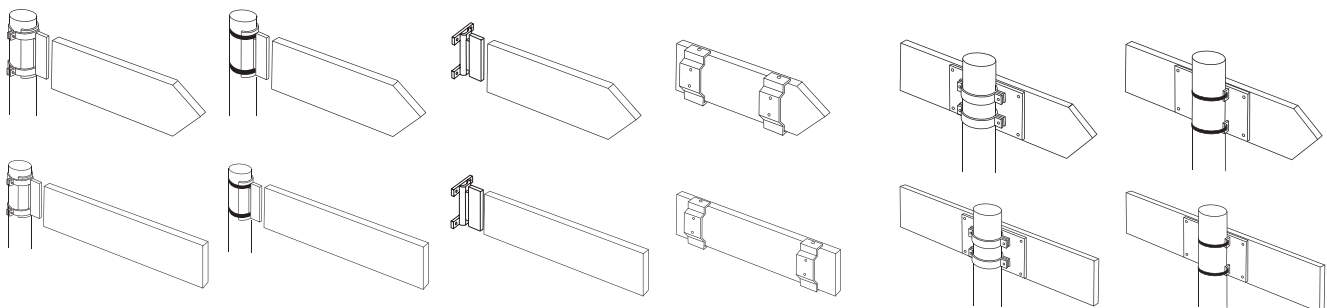

ST323
Alu-Befestigung für fahnenmässige Montage an Masten, mit Briden und Stahlband, Ø 60 mm oder andere Ø
Sostegno in alluminio per montaggio a bandiera e bride su pali con bride Ø 60 o altri Ø

ST323W
Alu-Befestigung für fahnenmässige Montage an Mauer mit Schrauben.
Sostegno in alluminio per montaggio a parete con viti.

ST325
Befestigung an Mauer mit Plastik-Dübel.
Pro Tafel 2 Stk. erforderlich.
Sostegno a parete con viti e tasselli in plastica. Per cartello 2 pezzi necessari.

ST348
Befestigungsplatte mit 2 Briden, feuerverzinkt, für Montage vor dem Mast.
Briden Ø 60 mm oder andere Ø (bitte Mast Ø angeben)
Placca di fissaggio con 2 bride, zincata, per montaggio centrale. Bride Ø 60 mm o altri Ø (indicare il Ø del palo)

ST348TB
Befestigungsplatte mit 2 Bügeln, feuerverzinkt, für Montage vor dem Mast mittels Stahlband. An Masten jeglichen Durchmessers ab Ø 60 mm
Placca di fissaggio con 2 manici, zincata, per montaggio centrale con nastro in acciaio, a partire di 60 mm di Ø

ST323 150 h = 150
ST323 200 h = 200

ST323W 150 h = 150
ST323W 200 h = 200

ST325W 150 h = 150
ST325W 200 h = 200

ST348 150 h = 150
ST348 200 h = 200

ST348TB 150 h = 150
ST348TB 200 h = 200

RM Ø = 60 mm
RM Ø = ind. mm

RM Ø = 60 mm
RM Ø = ind. mm

RM Ø = ind. mm

Preisliste
Listino prezzi

P5-24

P5-24

P5-25

P5-26

P5-27

Rohrmasten
Pali

32

32

32

32

32

Befestigungen Sostegni

Befestigungen für Wegweiskombinationen aus Alu-Holprofil (Merkel) Sostegni per combinazioni d'indicatori in alluminio sciolato (Merkel)

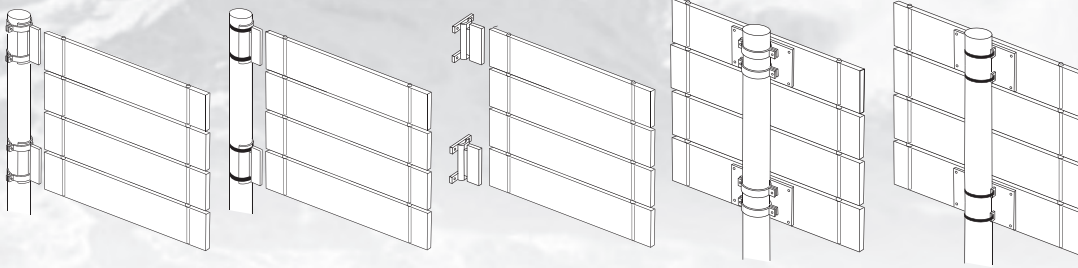

* Wegweiser Indicatori	Stk. Pzi
2-4	2
5-8	3
8-10	4

ST323
Alu-Befestigung für fahnenmässige Montage an Masten, mit Briden und Stahlband, Ø 60 mm oder andere Ø
Sostegno in alluminio per montaggio a bride e bandiera su pali, Ø 60 o altri Ø

ST323W
Alu-Befestigung für fahnenmässige Montage an Mauer mit Schrauben.
Sostegno in alluminio per montaggio a parete con viti.

ST348
Befestigungsplatten mit 2 Briden, feuerverzinkt. Briden Ø 60 mm oder andere Ø (bitte Mast Ø angeben)
Placca di fissaggio con 2 bride, zincata, per montaggio con nastro. Bride Ø 60 mm o altri Ø (indicare il Ø del palo)

ST348TB
Platten mit 2 Bügeln, feuerverzinkt, für Montage mittels Stahlband an Masten jeglichen Ø ab 60 mm
Placca di fissaggio con 2 manici, zincata, per montaggio con nastro in acciaio, a partire di 60mm di Ø

Befestigung mit Verbindungsstäben
Fissaggio con barre di collegamento

2 Stäbe pro Kombination inkl. Arretierstücke, Distanzrollen und Schrauben
2 barre per ogni combinazione, pezzo d'arresto distanziatori e viti inclusi

Interner Hinweis:
WWK 2-12
Beispiel Artikel Nr:
WWK 4-150

Indicazione interna:
WWK 2-12
Esempio Art. No:
WWK 4-150

ST323 150* h = 150
ST323 200* h = 200

ST323W 150 h = 150
ST323W 200 h = 200

ST348 150 h = 150
ST348 200 h = 200

ST348TB 150 h = 150
ST348TB 200 h = 200

RM Ø = 60 mm
RM Ø = ind. mm

RM Ø = 60 mm
RM Ø = ind. mm

RM Ø = > 60 mm

Preisliste Listino prezzi		P5-23	P5-24	P5-26	P5-27	P5-29
Rohrmasten Pali	Seite pagina	32	32	32	32	

Befestigungen für Strassennamenschilder aus Aluminiumguss Sostegni per targhe per toponomastica in alluminio pressofuso

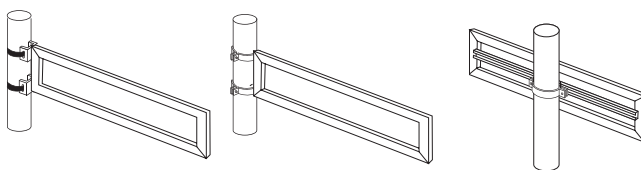

R143VC...
Fahnenmässige Montage an Masten mit Vierkantrahmen und Stahlband, Rohrmasten ab Ø 60 mm
Montaggio a bandiera su pali con telaio quadro e nastro in acciaio, pali a partire da Ø 60 mm

R143V...
Fahnenmässige Montage an Masten mit Briden, feuerverzinkt, Ø 60 mm oder Briden mit anderen Ø
Montaggio a bandiera su pali con bride zincate, Ø 60 mm o altri Ø

R143VJ
Träger mit Jordahlschiene, feuerverzinkt, Ø 60 mm oder Briden mit anderen Ø
Fissaggio con sistema "Jordal", zincato, Ø 60 o bride di altri Ø

R143VCES
R143VCDS

R143VES
R143VDS

R143VJ

ES = Einseitig/1 lato
DS = Beidseitig/doppio lato

RM Ø = > 60 mm

RM Ø = 60 mm
RM Ø = ind. mm

RM Ø = 60 mm
RM Ø = ind. mm

Preisliste Listino prezzi		P5-31	P5-31	P5-31
Rohrmasten Pali	Seite pagina	32	32	32

Signalträger Supporti per segnali

Signaflex R54F

mit Fundamentsockel, Mauerbride
oder zum Einbetonieren
*con zoccolo di fondazione,
brida murale o da cementare*

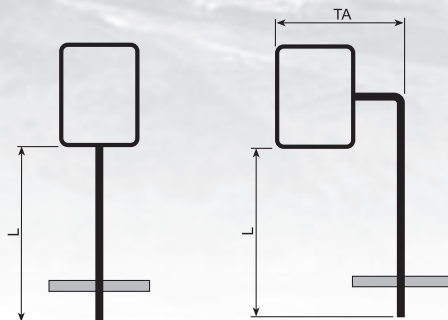

R54F

Format/o =	350 x 500
Format/o =	426 x 750
Format/o =	500 x 700
Format/o =	700 x 1000
L =	1600
L =	2100
L =	2500
L =	2800
L =	3100
L =	... (ind.)

R54FA

Format/o =	350 x 500
Format/o =	426 x 750
Format/o =	500 x 700
Format/o =	700 x 1000
L =	3000
L =	... (ind.)
TA (350x500) =	770
TA (426x750) =	850
TA (500x700) =	920
TA (700x1000) =	1140
TA =	... (ind.)

mit Flanschbefestigung
oder Bodenhülse
*con flangia di fissaggio o
tubo fodera*

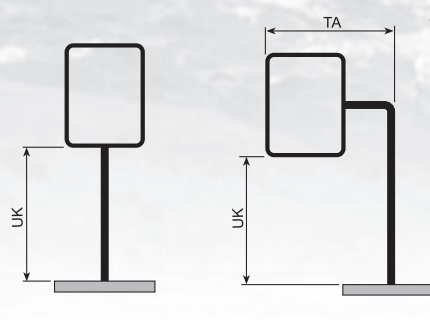

R54F

Format/o =	350 x 500
Format/o =	426 x 750
Format/o =	500 x 700
Format/o =	700 x 1000
UK =	2100
UK =	2500
UK =	2800
UK =	... (ind.)

R54FA

Format/o =	350 x 500
Format/o =	426 x 750
Format/o =	500 x 700
Format/o =	700 x 1000
UK =	2500
UK =	... (ind.)
TA (350x500) =	770
TA (426x750) =	850
TA (500x700) =	920
TA (700x1000) =	1140
TA =	... (ind.)

R56

mit Fundamentsockel,
Mauerbride oder
zum Einbetonieren
*con zoccolo di fondazione,
brida murale o da cementare*

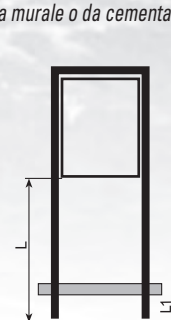

R56

Format/o =	500 x 700
L =	1200
L =	... (ind.)

Preisliste Listino prezzi

P5-32

P5-33

P5-34

Verankerung Ancoraggi

Seite
pagina

33

33

33

Signaflex R53F

mit Fundamentsockel, Mauerbride
oder zum Einbetonieren
*con zoccolo di fondazione,
brida murale o da cementare*

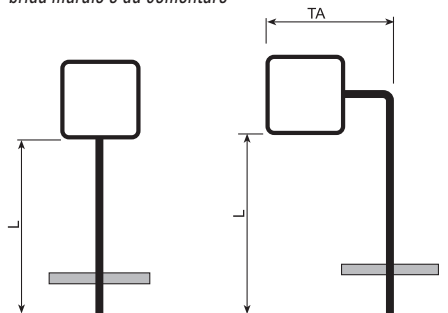

R53F

Format/o =	350
Format/o =	500
Format/o =	700
L =	1600
L =	2100
L =	2500
L =	2800
L =	3100
L =	... (ind.)

R53FA

Format/o =	350
Format/o =	500
Format/o =	700
L =	3000
L =	... (ind.)
TA (350) =	780
TA (500) =	930
TA (700) =	1130
TA =	... (ind.)

mit Flanschbefestigung
oder Bodenhülse
*con flangia di fissaggio o
tubo fodera*

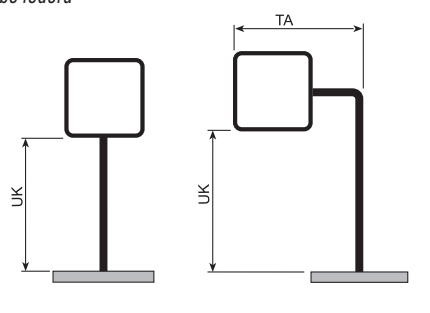

R53F

Format/o =	350
Format/o =	500
Format/o =	700
UK =	2100
UK =	2500
UK =	2800
UK =	... (ind.)

R53FA

Format/o =	350
Format/o =	500
Format/o =	700
UK =	2500
UK =	... (ind.)
TA (350) =	780
TA (500) =	930
TA (700) =	1130
TA =	... (ind.)

R55

mit Fundamentsockel,
Mauerbride oder
zum Einbetonieren
*con zoccolo di fondazione,
brida murale o da cementare*

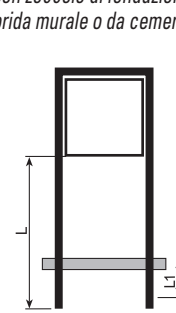

R55

Format/o =	500
L =	1200
L =	... (ind.)

Preisliste Listino prezzi

P5-35

P5-36

P5-37

Verankerung Ancoraggi

Seite
pagina

33

33

33

Signalträger Supporti per segnali

Signaflex R54F

mit Fundamentsockel, Mauerbride
oder zum Einbetonieren
*con zoccolo di fondazione,
brida murale o da cementare*

mit Flanschbefestigung
oder Bodenhülse
*con flangia di fissaggio o
tubo fodera*

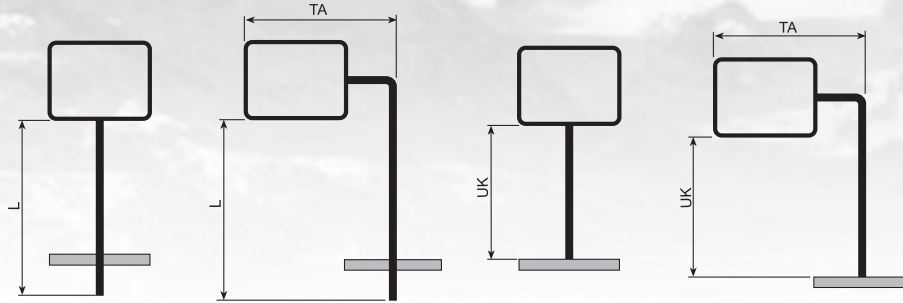

R64F

Format/o =	700 x 500
Format/o =	1000 x 700
L =	1600
L =	2100
L =	2500
L =	2800
L =	3100
L =	... (ind.)

R64FA

Format/o =	700 x 500
Format/o =	1000 x 700
L =	3000
L =	... (ind.)
TA (700x500) =	1120
TA (1000x700) =	1440
TA =	... (ind.)

R64F

Format/o =	700 x 500
Format/o =	1000 x 700
UK =	2100
UK =	2500
UK =	2800
UK =	... (ind.)

R64FA

Format/o =	700 x 500
Format/o =	1000 x 700
UK =	2500
UK =	... (ind.)
TA (700x500) =	1120
TA (1000x700) =	1440
TA =	... (ind.)

Preisliste
Listino prezzi

P5-38

P5-39

Verankerung
Ancoraggi

Seite
pagina

33

33

5

TOURISTISCHE SIGNALISATION UND STRASSENAMEN
SEGNALETICA TURISTICA E TOPONOMASTICA



Signalträger Supporti per segnali

Signaflex R71F

mit Fundamentsockel, Mauerbride oder zum Einbetonieren
con zoccolo di fondazione, brida murale o da cementare

mit Flanschbefestigung oder Bodenhülse
con flangia di fissaggio o tubo fodera

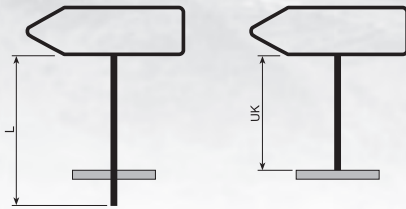

R71F

Format/o = 1020 x 250
Format/o = 1300 x 250
Format/o = 1300 x 350
Format/o = ... (ind.)

L = 1600
L = 2100
L = 2500
L = 2800
L = 3100
L = ... (ind.)

R71F

Format/o = 1020 x 250
Format/o = 1300 x 250
Format/o = 1300 x 350
Format/o = .. (ind.)

UK = 2100
UK = 2500
UK = 2800
UK = ... (ind.)

Preisliste
Listino prezzi

P5-40

P5-41

Verankerung
Ancoraggi

Seite
pagina

33

33

Signaflex 271F

mit Fundamentsockel, Mauerbride oder zum Einbetonieren
con zoccolo di fondazione, brida murale o da cementare

mit Flanschbefestigung oder Bodenhülse
con flangia di fissaggio o tubo fodera

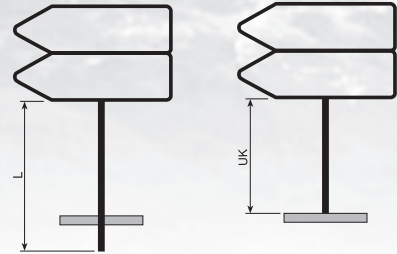

R271F

Format/o = 1020 x 250
Format/o = 1300 x 250
Format/o = 1300 x 350
Format/o = ... (ind.)

L = 1600
L = 2100
L = 2500
L = 2800
L = 3100
L = ... (ind.)

R271F

Format/o = 1020 x 250
Format/o = 1300 x 250
Format/o = 1300 x 350
Format/o = ... (ind.)

UK = 2100
UK = 2500
UK = 2800
UK = ... (ind.)

Preisliste
Listino prezzi

P5-43

P5-44

Verankerung
Ancoraggi

Seite
pagina

33

33

Signaflex R276F

mit Fundamentsockel, Mauerbride oder zum Einbetonieren
con zoccolo di fondazione, brida murale o da cementare

mit Flanschbefestigung oder Bodenhülse
con flangia di fissaggio o tubo fodera

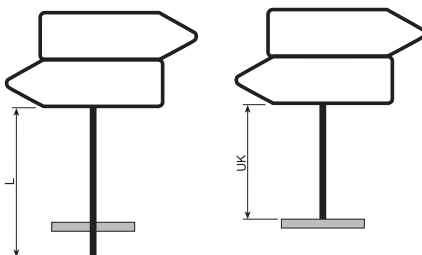

R276F

Format/o = 1020 x 250
Format/o = 1300 x 250
Format/o = 1300 x 350
Format/o = ... (ind.)

L = 1600
L = 2100
L = 2500
L = 2800
L = 3100
L = ... (ind.)

R276F

Format/o = 1020 x 250
Format/o = 1300 x 250
Format/o = 1300 x 350
Format/o = ... (ind.)

UK = 2100
UK = 2500
UK = 2800
UK = ... (ind.)

Preisliste
Listino prezzi

P5-43

P5-44

Verankerung
Ancoraggi

Seite
pagina

33

33

Signalträger Supporti per segnali

Einzelteile zu Signaflex Pezzi separati per Signaflex



A54F
Format/o = 350 x 500
Format/o = 500 x 700
Format/o = 426 x 750
Format/o = 700 x 1000



A64F
Format/o = 500 x 350
Format/o = 700 x 500
Format/o = 1000 x 700



A71F
Format/o = 1020 x 250
Format/o = 1300 x 250
Format/o = 1300 x 350
Format/o = ... (ind.)



A271F
Format/o = 1020 x 250
Format/o = 1300 x 250
Format/o = 1300 x 350
Format/o = ... (ind.)



A276F
Format/o = 1020 x 250
Format/o = 1300 x 250
Format/o = 1300 x 350
Format/o = ... (ind.)

A54FA
Format/o = 426 x 750

Preisliste <i>Listino prezzi</i>		P5-46		P5-46		P5-47		P5-48		P5-48
Rohrmasten Ø 60 Pali Ø 60	Seite pagina	32		32		32		32		32



A64F
Format/o = 700 x 500
Format/o = 1000 x 700



A54F
Format/o = 500 x 700
Format/o = 700 x 1000



A53F
Format/o = 350
Format/o = 500
Format/o = 700



A53F
Format/o = 350
Format/o = 500
Format/o = 700



KUP
Verbindungsstück
Pezzo di raccordo

Preisliste <i>Listino prezzi</i>		P5-46		P5-46		P5-49		P5-49		P5-50
Rohrmasten Ø 60 Pali Ø 60	Seite pagina	32		32		32		32		

Signalträger mit seitlicher Befestigung (Typ C) Supporti per segnali con fissaggio laterale (Tipo C)



R78C
Format/o = 1020 x 250
Format/o = 1300 x 250
Format/o = 1300 x 350



R80C
Format/o = 1020 x 250
Format/o = 1300 x 250
Format/o = 1300 x 350

Preisliste <i>Listino prezzi</i>		P5-51		P5-51
Halterungen Fissaggi	Seite pagina	31		31



R381C
Format = 350 x 500
Format = 426 x 750
Format = 500 x 700
Format = 700 x 1000



R381C
Format = 900 x 1250



R391C
Format = 700 x 500
Format = 1000 x 700

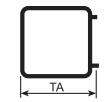

R361C
Format = 500
Format = 700

Masse Ausladung (A)
siehe Kapitel 1
Misura della sporgenza (A) cfr. capitolo 1

Preisliste <i>Listino prezzi</i>		P5-53		P5-54		P5-55
Halterungen Fissaggi	Seite pagina	31		31		31

Signalträger Supporti per segnali

Signalträger mit Jordahlschienen (Typ J) Telai per fissaggio con sistema Jordahl (tipo J)

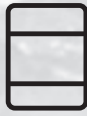

R382J

Format/o= 350 x 500
Format/o= 426 x 750
Format/o= 500 x 700
Format/o= 700 x 900

Halterung/Fissaggio
= SNT-2606 (28/15")
= SNT-2627 TB

Format/o= 700 x 1000
Format/o= 900 x 1250

Halterung/Fissaggio
= SNT-2607 (36/20")
= SNT-2628 TB



R392J

Format/o= 700 x 500
= 1000 x 700*

Halterung/Fissaggio
= SNT-2606 (28/15")
= SNT-2627 TB
= SNT-2607 (36/20")*
= SNT-2628 TB*



R362J

Format/o= 200 **
Format/o= 350
Format/o= 500
Format/o= 700

Halterung/Fissaggio
= SNT-2606 (28/15")
= SNT-2627 TB

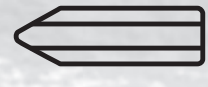

R79J

Format/o= 1020 x 250
Format/o= 1300 x 250
Format/o= 1300 x 350
Format/o=... (ind.)

Halterung/Fissaggio
= SNT-2606 (28/15")
= SNT-2627 TB

Preisliste Listino prezzi

Halterungen, Rohrmasten
Fissaggi, Pali

Seite
pagina

P5-56

31, 32

P5-56

31, 32

P5-57

31, 32

P5-58

31, 32

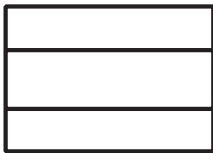

R142VJH

Horizontale Jordahlschienen
Binari "Jordahl" orizzontali



R142VJV

Vertikale Jordahlschienen
Binari "Jordahl" verticali

Tafelgröße Halterungen
Dimensioni cartello Fissaggi

< 2.1 m ²	→	SNT-2607
2.1 - 5.0 m ²	→	SNT-2607 (Montage an 2 Masten/Montaggio su 2 pali) SNT-2607A (Montage an 1 Mast/Montaggio su 1 palo)
> 5.0 m ²	→	SNT-2614A

Preisliste Listino prezzi

Halterungen, Rohrmasten
Fissaggi, Pali

Seite
pagina



31, 32

Signaltafel in Alu-Profilbauweise Tavola segnaletica in profilato d'alluminio

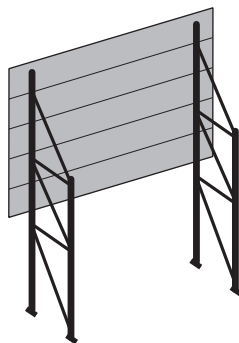

Alu-Profil/Profilato in alluminio
Format/o = ☎

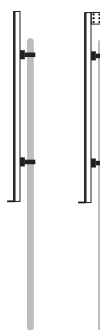

R142M
T-Befestigung zu FWS/
Menziken
Fissaggio-T per portasegnali
a serpentina FWS/Menziken

Format/o = ☎

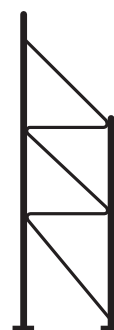

FWS
Fachwerkstützen
Portasegnali a
serpentina

Format/o = ☎

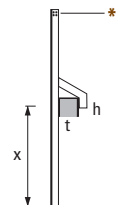

h (Höhe) / t (Tiefe)
x (Distanz UK bis Mitte Signal)
h (altezza) / t (profondità)
x (distanza da spigolo inferiore
a metà segnale)

NP
NP-Träger mit Bügel
Profilo NP con
staffa

Format/o = ☎

Preisliste Listino prezzi



5
TOURISTISCHE SIGNALISATION UND STRASSENAMEN
SEGNALETICA TURISTICA E TOPONOMASTICA
SIGNAL

Halterungen Fissaggi

mit Bride für Signalträger Typ J (Jordahl) con brida per telai tipo J (Jordahl)



an Rohrmast oder Kandelaber
su palo o candelabro

Bride Brida	Ø Rohrmast Ø Palo	Bride Brida	Ø Rohrmast Ø Palo
SNT-2606 60	Ø 60 mm	SNT-2607 60	Ø 60 mm
SNT-2606 76	Ø 76 mm	SNT-2607 76	Ø 76 mm
SNT-2606 89	Ø 89 mm	SNT-2607 89	Ø 89 mm
SNT-2606 102	Ø 102 mm	SNT-2607 102	Ø 102 mm
SNT-2606 108	Ø 108 mm	SNT-2607 108	Ø 108 mm
SNT-2606 114	Ø 114 mm	SNT-2607 114	Ø 114 mm
SNT-2606 121	Ø 121 mm	SNT-2607 121	Ø 121 mm
SNT-2606 127	Ø 127 mm	SNT-2607 127	Ø 127 mm
SNT-2606 133	Ø 133 mm	SNT-2607 133	Ø 133 mm
SNT-2606 140	Ø 140 mm	SNT-2607 140	Ø 140 mm
SNT-2606 152	Ø 152 mm	SNT-2607 152	Ø 152 mm
SNT-2606 168	Ø 168 mm	SNT-2607 168	Ø 168 mm
SNT-2606 178	Ø 178 mm	SNT-2607 178	Ø 178 mm
SNT-2606 193	Ø 193 mm	SNT-2607 193	Ø 193 mm
SNT-2606 198	Ø 198 mm	SNT-2607 198	Ø 198 mm
SNT-2606	Ø ind.	SNT-2607	Ø ind.

(28/15*) (36/20*)

Preisliste
Listino prezzi

P5-59

mit Bride für Signalträger Typ C con brida per supporti per segnali tipo C

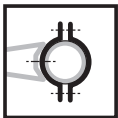

an Rohrmast oder Kandelaber
su palo o candelabro

Bride Brida	Ø Rohrmast Ø Palo	Bride Brida	Ø Rohrmast Ø Palo
SNT-2039 60	Ø 60 mm	SNT-2039 133	Ø 133 mm
SNT-2039 76	Ø 76 mm	SNT-2039 140	Ø 140 mm
SNT-2039 89	Ø 89 mm	SNT-2039 152	Ø 152 mm
SNT-2039 102	Ø 102 mm	SNT-2039 168	Ø 168 mm
SNT-2039 108	Ø 108 mm	SNT-2039 178	Ø 178 mm
SNT-2039 114	Ø 114 mm	SNT-2039 193	Ø 193 mm
SNT-2039 121	Ø 121 mm	SNT-2039 198	Ø 198 mm
SNT-2039 127	Ø 127 mm	SNT-2039	Ø ind.

Preisliste
Listino prezzi

P5-60

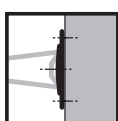

an Wand
a parete

SNT-2039 W

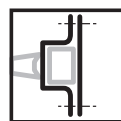

an Vierkantrahmen
a telaio profilato
quadro

SNT-2039 E

Preisliste
Listino prezzi

P5-61

* Dimension der Jordahlschiene/Dimensione del binario Jordahl

mit Bügel für Signalträger Typ J und C con brida per telai tipo J e C



an Rohrmast oder Kandelaber
su palo o candelabro

SNT-2627TB (28/15*)
SNT-2628TB (36/20*)

Bügel für Tespaband- oder Schlauchbridenmontage für Typ J. / Brida per montaggio con nastro Tespa o brida a nastro per tipo J.



Tespaband (TB 19) und Schlauchbriden (TBS 19) für Befestigung der Typen J und C siehe unten. Per nastro Tespa e bracciali per tipi J e C vedi sotto.

Preisliste
Listino prezzi

P5-62

mit Briden für Signalträger R142VJ con brida per telai R142VJ

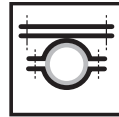

SNT-2607 (36/20*)
SNT-2614 (50/30*)

Bride zu Jordahlschiene
Brida per binario Jordahl

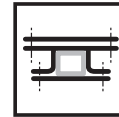

SNT-2608 (36/20*)
SNT-2608G (50/30*)

Rechteckbride
Brida rettangolare

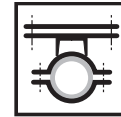

SNT-2607A (36/20*)
SNT-2614A (50/30*)

Bride zu Jordahlschiene
Brida per binario Jordahl

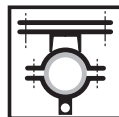

SNT-2607B (36/20*)
SNT-2614B (50/30*)

Bride zu Jordahlschiene
Brida per binario Jordahl

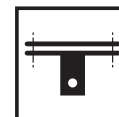

SNT-2607C (36/20*)
SNT-2614C (50/30*)

Traversenhalterung
zu SNT-...B/
Appoggio della barra
trasversale SNT-...B



TR (Ø 42, l = ind.)

Traverse von
SNT-...B zu SNT-...C
Barra trasversale da
SNT-...B a SNT-...C

Preisliste
Listino prezzi

☎

Befestigungsmaterial Materiale di fissaggio

Briden/Bride
rostfrei/acciaio inossidabile

ST323-1 Ø 60 mm,
andere Ø/altri Ø

Schlauchbriden/Bride a nastro
rostfrei/acciaio inossidabile

SB6348 Ø 42 - 90 mm
SB6364 Ø 67 - 114 mm
SB6388 Ø 108 - 153 mm
SB ENDLOS Ø 66 - 406 mm

TESPA
Stahlband/Nastro in acciaio

TB-K TESPA-Kasten/Cofanetto TESPA
TB-W TESPA-Werkzeug/Utensile di
serraggio TESPA

TB 10 10 mm, 3/8" x 30 m Band/nastro
TB 13 13 mm, 1/2" x 30 m Band/nastro
TB 16 16 mm, 5/8" x 30 m Band/nastro
TB 19 19 mm, 3/4" x 30 m Band/nastro
TBS 10 10 mm, 3/8", 100 Schlaufen/staffe
TBS 13 13 mm, 1/2", 100 Schlaufen/staffe
TBS 16 16 mm, 5/8", 100 Schlaufen/staffe
TBS 19 19 mm, 3/4", 100 Schlaufen/staffe

Preisliste
Listino prezzi

P5-28

5

TOURISTISCHE SIGNALISATION UND STRASSENAMEN
SEGNALETICA TURISTICA E TOPONOMASTICA



Rohrmasten Pali

Rohrmasten RM60 zu Signaflex Pali RM60 per Signaflex

für Fundamentsockel oder zum Einbetonieren
con zoccolo di fondazione o da cementare

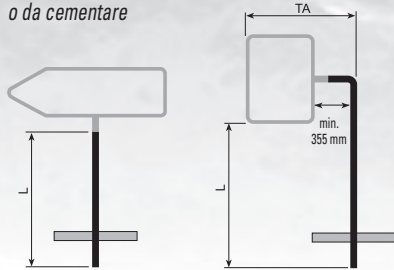

RM60 L = 1500
L = 2000
L = 2400
L = 2700
L = 3000
L = ... (ind.)

für Flanschbefestigung oder Bodenhülse
con flangia di fissaggio o tubo fodera

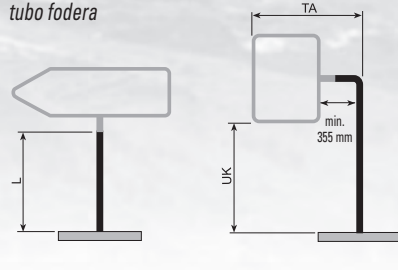

RM60 L = 1500
L = 2000
L = 2400
L = 2700
L = 3000
L = ... (ind.)

RMFA60 L = 3000
L = .. (ind.)
TA = siehe Träger
komplett Seite 25/
supporti completi
vedi pag. 25

Rohrmasten Pali

für Fundamentsockel oder zum Einbetonieren
con zoccolo di fondazione o da cementare

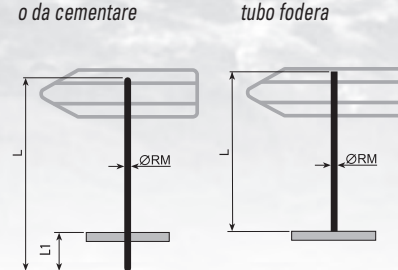

RM60 L = 1500 L1 = 500
L = 2000 L1 = 500
L = 2400 L1 = 500
L = 2700 L1 = 500
L = 3000 L1 = 500
L = 3600 L1 = 500
L = 4000 L1 = 500
L = ... (ind.) L1 = 500

für Flanschbefestigung oder Bodenhülse
con flangia di fissaggio o tubo fodera

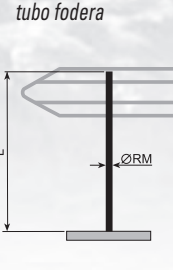

RM60 L = 1500
L = 2000
L = 2400
L = 2700
L = 3000
L = ... (ind.)

RM76 L = ... (ind.)
RM89 L = ... (ind.)

Rohrmasten mit $\varnothing > 89$ mm auf Anfrage. Bauseitige Fundamente erforderlich. Pali con $\varnothing > 89$ mm su richiesta. Necessaria esecuzione fondazione in loco.

RM76 L = 3600 L1 = 600
L = ... (ind.) L1 = 600

RM89 L = 3600 L1 = 600
L = ... (ind.) L1 = 600

Beispiel/eseempio:
RM60/1500

Beispiel/eseempio:
RMFA60/3000

Beispiele/eseempi:
RM60/1500 SCH *
RM60/1500 FL3
RM60/1500 FL4

Beispiele/eseempi:
RMFA60/2500 SCH *
RMFA60/2500 FL3
RMFA60/2500 FL4

Beispiel/eseempio:
RM60/1500 D

Beispiele/eseempi:
RM60/1500 SCH D *
RM60/1500 FL3 D
RM60/1500 FL4 D

Preisliste Listino prezzi

P5-63

Verankerungen Ancoraggi

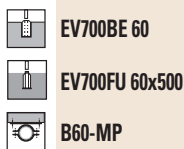

Seite
pagina 33

P5-64

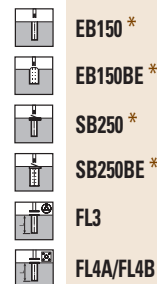

Seite
pagina 33

P5-63

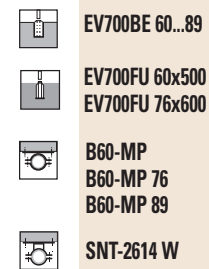

Seite
pagina 33

P5-64

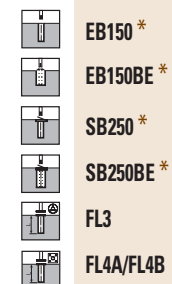

Seite
pagina 33

Empfohlene Zuordnungen für Rohrmasten Raccomandazioni per pali

Rohrmast Palo	Ø 60	Ø 76	Ø 89
Signale [mm] Segnale [mm]	Normalformat Formato normale	Zwischenformat Formato intermedio	Grossformat Grande formato
	500 x 700 700 x 500	700 x 1000 1000 x 700	900 x 1250 1250 x 900
	500 x 500	700 x 700	900 x 900
Statik gemäss SIA 261 bei einem Staudruck von 0,9 kN/m ² . Gültig für 1 Signaltafel pro Rohrmast, Montage UK 2000 mm. / Statica secondo SIA 261 per una pressione del vento di 0,9 kN/m ² . Valido per 1 tavola segnaletica per palo, montaggio altezza lato inferiore segnale a 2000 mm.			

Oberer Abschluss des Rohrmastes Chiusura superiore del palo

RM60 = oben ohne Deckel, senza coperchio sopra
RM60 ...D = oben mit Deckel, con coperchio sopra
Beispiel/eseempio: **RM60/1500 D**
RM76 ...D = oben mit Deckel, con coperchio sopra
RM89 ...D = oben mit Deckel, con coperchio sopra

* nur für Rohr Ø 60, Rohrmasten inkl. Schloss SCH400, optional Schlüssel SCH420
solamente per Ø 60, palo con chiusura incl. SCH400, opzione chiave SCH420

Verankerungen Ancoraggi

Fundamentsockel, Mauerbride oder zum Einbetonieren Zoccolo di fondazione, brida murale o da cementare

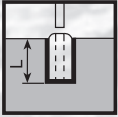

Fundamentsockel
Zoccolo di fondazione

- Ø 33 = EV700BE 33 L = 300
- Ø 48 = EV700BE-K 48 L = 300
- Ø 48 = EV700BE 48 L = 500
- Ø 60 = EV700BE 60 * L = 500
- Ø 76 = EV700BE 76 L = 600
- Ø 89 = EV700BE 89 L = 600

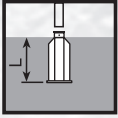

Stahlfundament
Fondazione in acciaio

- Ø 48 = EV700FU 48X500 L = 500
- Ø 60 = EV700FU 60X300 L = 300
- Ø 60 = EV700FU 60X500 L = 500
- Ø 76 = EV700FU 76X600 L = 500

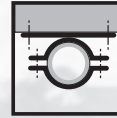

Bride zur Befestigung von
Rohrmast an Mauer
Brida per fissaggio di palo a parete

- Ø 60 = B60-MP *
- Ø 76 = B60-MP 76
- Ø 89 = B60-MP 89

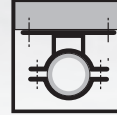

Ø ind. = SNT-2614 W

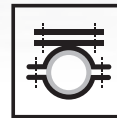

Bride zur Befestigung an WR Clip
Brida per montaggio su WR Clip

- Ø 60 = BR 60 ALU **
- Ø 76 = BR 76 ALU **
- Ø 90 = BR 90 ALU **
- Ø 33 = BR 33 FV **

Optionen zu EV700BE/Opzioni per EV700BE

Gummidichtung
für Rohrmast
Guarnizione in
caoutchouc per palo

- Ø 33 = EV1 33
- Ø 48 = EV1 48
- Ø 60 = EV1 60 *
- Ø 76 = EV1 76
- Ø 89 = EV1 89

Abschlussdeckel
Coperchio di chiusura

- Ø 33 = EV2 33
- Ø 48 = EV2 48
- Ø 60 = EV2 60 *
- Ø 76 = EV2 76
- Ø 89 = EV2 89

Schutzkappe für
Coperchio di protezione
per vite

EV3



Preisliste
Listino prezzi

P5-65

P5-14 **

* für Signaflex nur in dieser Grösse erhältlich
unica dimensione adatta per Signaflex

Flanschbefestigung oder Bodenhülse Flangia di fissaggio o tubo fodera

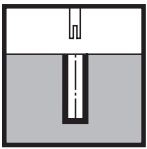

EB150
Bodenhülse
Tubo fodera

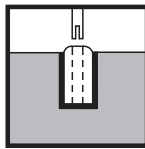

EB150BE
Bodenhülse in
Fundament
Tubo fodera
in fondazione

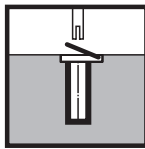

SB250
Bodenhülse mit
schwerem Deckel
Tubo fodera con
coperchio pesante

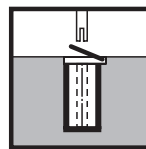

SB250BE
Bodenhülse in Funda-
ment mit schwerem
Deckel
Tubo fodera con
coperchio pesante in
fondazione

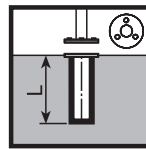

FL3
Flanschbefestigung
Flangia di fissaggio
L = 300
L = 400
L = 500

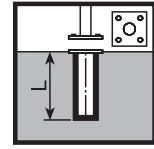

FL4A FL4B
Flanschbefestigung
Flangia di fissaggio
Ø 150 Ø 200
L = 300 L = 300
L = 400 L = 400
L = 500 L = 500

Preisliste
Listino prezzi

P5-66

Rohrmasten B33 und Betonsockel Palo B33 e base in cemento

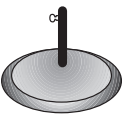

BE35
Betonsockel ca. 25 kg
mit feuerverzinktem
Rohrstutzen für 1"-Rohr
Base in cemento
rotonda, ca 25 kg,
con innesto per palo "1",
zincato

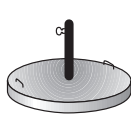

BE67
Betonsockel ca. 50 kg mit
Flacheisenring verstärkt,
mit feuerverzinktem Rohr-
stutzen für 1"-Rohr. Mit 2
Handgriffen.
Base in cemento, ca 50 kg,
rinforzata, con innesto per
palo "1", zincato, con 2
maniglie.

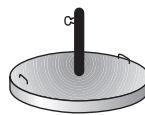

BE80
Betonsockel ca. 80 kg mit
Flacheisenring verstärkt,
mit feuerverzinktem Rohr-
stutzen für 1"-Rohr. Mit 2
Handgriffen.
Base in cemento, ca 80 kg,
rinforzata, con innesto per
palo "1", zincato, con 2
maniglie.



B33
L = 700
L = 1350
L = 1750
L = 2000
L = ... (ind.)

Preisliste
Listino prezzi

P5-67

